



Bid Number/बोली क्रमांक (बिड संख्या):  
GEM/2024/B/4868415  
Dated/दिनांक : 17-04-2024

### Bid Document/ बिड दस्तावेज़

Bid Details/बिड विवरण	
Bid End Date/Time/बिड बंद होने की तारीख/समय	08-05-2024 13:00:00
Bid Opening Date/Time/बिड खुलने की तारीख/समय	08-05-2024 13:30:00
Bid Offer Validity (From End Date)/बिड पेशकश वैधता (बंद होने की तारीख से)	120 (Days)
Ministry/State Name/मंत्रालय/राज्य का नाम	Ministry Of Power
Department Name/विभाग का नाम	Na
Organisation Name/संगठन का नाम	Ntpc Limited
Office Name/कार्यालय का नाम	Cg
Total Quantity/कुल मात्रा	120
Item Category/मद केटेगरी	GRINDING BALL BOILER (Q3) , HOLLOW FILLER BALL BOILER (Q3) , GRINDING RING SAO-MO2-SM-A3K-728-2 (Q3)
MSE Exemption for Years of Experience and Turnover/ अनुभव के वर्षों से एमएसई छूट	No
Startup Exemption for Years of Experience and Turnover/ अनुभव के वर्षों से स्टार्टअप छूट	No
Document required from seller/विक्रेता से मांगे गए दस्तावेज़	Experience Criteria,Bidder Turnover,Certificate (Requested in ATC),Additional Doc 1 (Requested in ATC),Additional Doc 2 (Requested in ATC),Additional Doc 3 (Requested in ATC),Additional Doc 4 (Requested in ATC),Compliance of BoQ specification and supporting document *In case any bidder is seeking exemption from Experience / Turnover Criteria, the supporting documents to prove his eligibility for exemption must be uploaded for evaluation by the buyer
Bid to RA enabled/बिड से रिवर्स नीलामी सक्रिय किया	No
Type of Bid/बिड का प्रकार	Two Packet Bid
Primary product category	GRINDING RING SAO-MO2-SM-A3K-728-2
Time allowed for Technical Clarifications during technical evaluation/तकनीकी मूल्यांकन के दौरान तकनीकी स्पष्टीकरण हेतु अनुमत समय	3 Days
Inspection Required (By Empanelled Inspection Authority / Agencies pre-registered with GeM)	No

**Bid Details/बिड विवरण****Evaluation Method/मूल्यांकन पद्धति**

Total value wise evaluation

**EMD Detail/ईएमडी विवरण**

Advisory Bank/एडवाइजरी बैंक

ICICI

EMD Amount/ईएमडी राशि

500000

**ePBG Detail/ईपीबीजी विवरण**

Advisory Bank/एडवाइजरी बैंक

ICICI

ePBG Percentage(%) / ईपीबीजी प्रतिशत (%)

5.00

Duration of ePBG required (Months) / ईपीबीजी की अपेक्षित अवधि (महीने).

24

(a). EMD EXEMPTION: The bidder seeking EMD exemption, must submit the valid supporting document for the relevant category as per GeM GTC with the bid. Under MSE category, only manufacturers for goods and Service Providers for Services are eligible for exemption from EMD. Traders are excluded from the purview of this Policy./जेम की शर्तों के अनुसार ईएमडी छूट के इच्छुक बिडर को संबंधित केटेगरी के लिए बिड के साथ वैध समर्थित दस्तावेज प्रस्तुत करने हैं। एमएसई केटेगरी के अंतर्गत केवल वस्तुओं के लिए विनिर्माता तथा सेवाओं के लिए सेवा प्रदाता ईएमडी से छूट के पात्र हैं। व्यापारियों को इस नीति के दायरे से बाहर रखा गया है।

(b). EMD & Performance security should be in favour of Beneficiary, wherever it is applicable./ईएमडी और संपादन जमानत राशि, जहां यह लागू होती है, लाभार्थी के पक्ष में होनी चाहिए।

**Beneficiary/लाभार्थी :**

GM (C&amp;M)-CPG-1

NTPC Limited, Western Region II Headquarters, Plot No-87, Sector-24, Atal Nagar, Naya Raipur, Raipur  
Chhatisgarh-492018

(Durga Prasad Pradhan)

**Splitting/विभाजन**

Bid splitting not applied/बोली विभाजन लागू नहीं किया गया.

**Reserved for Make In India products**

Reserved for Make In India products

Yes

**MSE Purchase Preference/एमएसई खरीद वरीयता**

MSE Purchase Preference/एमएसई खरीद वरीयता

Yes

1. Bid reserved for Make In India products: : Procurement under this bid is reserved for purchase from Class 1 local supplier as defined in public procurement (Preference to Make in India), Order 2017 as amended from time to time and its subsequent Orders/Notifications issued by concerned Nodal Ministry for specific Goods/Products. However, eligible micro and small enterprises will be allowed to participate. The minimum local content to qualify as a class 1 local supplier is denoted in the bid document. All bidders must upload a certificate from the OEM regarding the percentage of the local content and the details of locations at which the local value addition is made along with their bid, failing which the bid is liable to be rejected. In case the bid value is more than Rs 10 Crore, the declaration relating to percentage of local content shall be certified by the statutory auditor or cost auditor, if the OEM is a company and by a practicing cost accountant or a chartered accountant for OEMs other than companies as per the Public Procurement (preference to Make-in -India) order 2017 dated 04.06.2020 . In case Buyer has selected Purchase preference to Micro and Small Enterprises clause in the bid, the same will get precedence over this clause.

2. Purchase preference to Micro and Small Enterprises (MSEs): Purchase preference will be given to MSEs as defined in Public Procurement Policy for Micro and Small Enterprises (MSEs) Order, 2012 dated 23.03.2012 issued by Ministry of Micro, Small and Medium Enterprises and its subsequent Orders/Notifications issued by concerned Ministry. If the bidder wants to avail the Purchase preference, the bidder must be the manufacturer of the offered product in case of bid for supply of goods. Traders are excluded from the purview of Public Procurement Policy for Micro and Small Enterprises. In respect of bid for Services, the bidder must be the Service provider of the offered Service. Relevant documentary evidence in this regard shall be uploaded along with the bid in respect of the offered product or service. If L-1 is not an MSE and MSE Seller (s) has/have quoted price within L-1+ 15% (Selected by Buyer)of margin of purchase preference /price band defined in relevant policy, such Seller shall be given opportunity to match L-1 price and contract will be awarded for 100%(selected by Buyer) percentage of total QUANTITY.The buyers are advised to refer the OM No.F.1/4/2021-PPD dated 18.05.2023 [OM No.1\\_4\\_2021\\_PPD\\_dated\\_18.05.2023](#) for compliance of Concurrent application of Public Procurement Policy for Micro and Small Enterprises Order, 2012 and Public Procurement (Preference to Make in India) Order, 2017.

## GRINDING BALL BOILER ( 100 pieces )

(Minimum 60% Local Content required for qualifying as Class 1 Local Supplier)

### Technical Specifications/तकनीकी विशिष्टियाँ

Buyer Specification Document/क्रेता विशिष्टि दस्तावेज़	<a href="#">Download</a>
--	--------------------------

### Consignees/Reporting Officer/परेषिती/रिपोर्टिंग अधिकारी and/ तथा Quantity/मात्रा

S.No./क्र. सं.	Consignee Reporting/Officer/ परेषिती/रिपोर्टिंग अधिकारी	Address/पता	Quantity/मात्रा	Delivery Days/डिलीवरी के दिन
1	Jayaraju Pagi	505215,Ramagundam Super Thermal Power Station PO JYOTINAGAR 505215 DISTRICT PEDDAPALLI	100	240

## HOLLOW FILLER BALL BOILER ( 10 pieces )

(Minimum 60% Local Content required for qualifying as Class 1 Local Supplier)

### Technical Specifications/तकनीकी विशिष्टियाँ

Buyer Specification  
Document/क्रेता विशिष्टि दस्तावेज़

[Download](#)

**Consignees/Reporting Officer/परेषिती/रिपोर्टिंग अधिकारी and/ तथा Quantity/मात्र**

S.No./क्र. सं.	Consignee Reporting/Officer/ परेषिती/रिपोर्टिंग अधिकारी	Address/पता	Quantity/मात्र	Delivery Days/डिलीवरी के दिन
1	Jayaraju Pagi	505215,Ramagundam Super Thermal Power Station PO JYOTINAGAR 505215 DISTRICT PEDDAPALLI	10	240

**GRINDING RING SAO-MO2-SM-A3K-728-2 ( 10 set )**

**(Minimum 60% Local Content required for qualifying as Class 1 Local Supplier)**

**Technical Specifications/तकनीकी विशिष्टियाँ**

Buyer Specification  
Document/क्रेता विशिष्टि दस्तावेज़

[Download](#)

**Consignees/Reporting Officer/परेषिती/रिपोर्टिंग अधिकारी and/ तथा Quantity/मात्र**

S.No./क्र. सं.	Consignee Reporting/Officer/ परेषिती/रिपोर्टिंग अधिकारी	Address/पता	Quantity/मात्र	Delivery Days/डिलीवरी के दिन
1	Jayaraju Pagi	505215,Ramagundam Super Thermal Power Station PO JYOTINAGAR 505215 DISTRICT PEDDAPALLI	10	240

**Buyer Added Bid Specific Terms and Conditions/क्रेता द्वारा जोड़ी गई बिड की विशेष शर्तें**

1. **Scope of Supply**

Scope of supply (Bid price to include all cost components) : Only supply of Goods

## 2. Certificates

Bidder's offer is liable to be rejected if they don't upload any of the certificates / documents sought in the Bid document, ATC and Corrigendum if any.

## 3. Buyer Added Bid Specific ATC

Buyer uploaded ATC document [Click here to view the file.](#)

## Disclaimer/अस्वीकरण

The additional terms and conditions have been incorporated by the Buyer after approval of the Competent Authority in Buyer Organization, whereby Buyer organization is solely responsible for the impact of these clauses on the bidding process, its outcome, and consequences thereof including any eccentricity / restriction arising in the bidding process due to these ATCs and due to modification of technical specifications and / or terms and conditions governing the bid. If any clause(s) is / are incorporated by the Buyer regarding following, the bid and resultant contracts shall be treated as null and void and such bids may be cancelled by GeM at any stage of bidding process without any notice:-

1. Definition of Class I and Class II suppliers in the bid not in line with the extant Order / Office Memorandum issued by DPIIT in this regard.
2. Seeking EMD submission from bidder(s), including via Additional Terms & Conditions, in contravention to exemption provided to such sellers under GeM GTC.
3. Publishing Custom / BOQ bids for items for which regular GeM categories are available without any Category item bunched with it.
4. Creating BoQ bid for single item.
5. Mentioning specific Brand or Make or Model or Manufacturer or Dealer name.
6. Mandating submission of documents in physical form as a pre-requisite to qualify bidders.
7. Floating / creation of work contracts as Custom Bids in Services.
8. Seeking sample with bid or approval of samples during bid evaluation process. (However, in bids for [attached categories](#), trials are allowed as per approved procurement policy of the buyer nodal Ministries)
9. Mandating foreign / international certifications even in case of existence of Indian Standards without specifying equivalent Indian Certification / standards.
10. Seeking experience from specific organization / department / institute only or from foreign / export experience.
11. Creating bid for items from irrelevant categories.
12. Incorporating any clause against the MSME policy and Preference to Make in India Policy.
13. Reference of conditions published on any external site or reference to external documents/clauses.
14. Asking for any Tender fee / Bid Participation fee / Auction fee in case of Bids / Forward Auction, as the case may be.

Further, if any seller has any objection/grievance against these additional clauses or otherwise on any aspect of this bid, they can raise their representation against the same by using the Representation window provided in the bid details field in Seller dashboard after logging in as a seller within 4 days of bid publication on GeM. Buyer is duty bound to reply to all such representations and would not be allowed to open bids if he fails to reply to such representations.

[This Bid is also governed by the General Terms and Conditions/ यह बिड सामान्य शर्तों के अंतर्गत भी शासित है](#)

In terms of GeM GTC clause 26 regarding Restrictions on procurement from a bidder of a country which shares a land border with India, any bidder from a country which shares a land border with India will be eligible to bid in this tender only if the bidder is registered with the Competent Authority. While participating in bid, Bidder has to undertake compliance of this and any false declaration and non-compliance of this would be a ground for immediate termination of the contract and further legal action in accordance with the laws./जेम की सामान्य शर्तों के खंड 26 के संदर्भ में भारत के साथ भूमि सीमा साझा करने वाले देश के बिडर से खरीद पर प्रतिबंध के संबंध में भारत के साथ भूमि सीमा साझा करने वाले देश का कोई भी बिडर इस निविदा में बिड देने के लिए तभी पात्र होगा

जब वह बिड देने वाला सक्षम प्राधिकारी के पास पंजीकृत हो।बिड में भाग लेते समय बिडर को इसका अनुपालन करना होगा और कोई भी गलत घोषणा किए जाने व इसका अनुपालन न करने पर अनुबंध को तत्काल समाप्त करने और कानून के अनुसार आगे की कानूनी कार्रवाई का आधार होगा।

**---Thank You/धन्यवाद---**

**NTPC LIMITED**  
**(A GOVERNMENT OF INDIA ENTERPRISE)**  
**Central Procurement Group-I, Raipur**

**INVITATION FOR BIDS (IFB)**  
**(DOMESTIC COMPETITIVE BIDDING)**

1. NTPC invites online bids on Single Stage-Two Envelope bidding basis for  
**"PROCUREMENT OF GRINDING BALLS & GRINDING RINGS FOR 8.5E10  
COAL MILLS, STAGE-I, NTPC RAMAGUNDAM"**.

**2. Brief Details:**

<b>NIT No.</b>	<b>NTPC/USSC-CPG1/ 9900278268</b>
<b>Tender Fees</b>	Not Applicable
<b>EMD</b>	<b>INR 5,00,000.00 (Five Lakhs Only)</b>
<b>Completion period</b>	Within 240 days

**General Terms & Conditions:**

1. NTPC reserves the right to assess bidder's capability and capacity of the bidder for carrying out the supplies and the decision of NTPC in this regard shall be final.
2. NTPC reserves the right to accept or reject any or all the tenders in part or full including rejection of any request for issue of tender documents, alter the quantities or split the order without assigning any reason thereof.
3. Above details are only indicative. Other detailed terms and conditions shall be as per tender documents.

**Address for Communication:**

GM (C&M)-CPG-1  
NTPC Limited, Western Region II Headquarters,  
Plot No-87, Sector-24, Atal Nagar,  
Naya Raipur, Raipur  
Chhatisgarh-492018  
Email:- [dppradhan@ntpc.co.in](mailto:dppradhan@ntpc.co.in)/[amitksingh@ntpc.co.in](mailto:amitksingh@ntpc.co.in)

**Contact Person:**

1. Amit Kumar Singh, AGM(C&M), 9415335083
2. Durga Prasad Pradhan, GM(C&M), 7008084608/ 9437043570

## **BUYER ADDED ADDITIONAL TERMS & CONTIONS (ATC)**

### **I. TERMS & CONDITIONS:**

1. **Delivery/ Completion Period:** Within 240 days from PO

- Vendor has to supply grinding balls and ring in sets:  
01 set = 10 No grinding balls+ 01 Filler Ball + top ring + bottom ring
- Lead time to start the delivery after placement of PO shall be 90 Days Max.
- Thereafter, Vendor has to supply 02 sets every month.
- Complete the delivery within 08 months from date of PO.

(03 Months Lead time) + (10/02= 5 Months) = 08 Months (240 days)

2. **Inspection:** Pre dispatch inspection (PDI) shall be carried out by NTPC RIO at the works of vendor as per technical specification, standard quality plan. Vendor has to accept the NTPC standard quality plan. Materials are to be dispatched only after issue of MDCC from NTPC.

3. **Payment Term:** 100% payment within 10 days of Consignee's Receipt & Acceptance Certificate (CRAC) Generation in GeM.

4. **WARRANTY / GUARANTEE:** The grinding balls and rings shall be guaranteed as a set consisting of 10 no. of hollow grinding balls, 1 no. hollow filler ball, top ring and bottom ring for a minimum wear life of 4500 running hours per set. Details as per Technical Specifications.

5. **PBG (Performance bank Guarantee):** PBG for an amount equal to **5%** of total order value of GeM Contract to be submitted within 30 days of placement of award. PBG should initially be valid for a period of 24 months and should be suitably extended to cover the guarantee period of 4500 running hours for all the sets.

### **II. ELIGIBILITY FOR PARTICIATION IN TENDER:**

'Class-I local suppliers' only are eligible to participate in this tender, as defined in the bidding documents/ Public Procurement (Preference to Make in India), Order 2017 and its subsequent amendments/ revisions issued by DPIIT. The bidders may apprise themselves of the relevant provisions of bidding documents in this regard before submission of their bids."

**The minimum local content shall be 60%.**

The 'Class-I local supplier' shall be required to provide, in the Bid Form/relevant attachment of Techno- Commercial bid, self-certification/declaration that the Item offered meets the local content requirement for 'Class-I local supplier' and shall give



details of the location(s) at which the local value addition is made. Format is attached as **Annexure A**.

Bids for item(s) which do not meet the Minimum Local Content as mentioned above, shall be considered non-responsive and shall not be evaluated in respect of such item(s) i.e. shall be rejected for such item(s).

In case false declaration in respect of Local content, same shall be treated as false declaration and will be dealt in line with the Fraud Prevention Policy of NTPC. +

## Annexure A

### Declaration of Local content

Bidding Document No:.....

Dear Sir,

- 1.1 We have read the provisions of “Preference to Make in India and Eligibility for granting of Purchase Preference to Class-I local suppliers” enclosed with the Bid Data Sheets.

In terms of the requirement of the aforesaid provisions, we hereby declare that we have submitted our bids for only those item(s) for which we are eligible for participation as per provisions of the Bidding documents and we are Class-I local supplier for all such items.

The details of the location(s) at which the local value addition is made are as under:

Sl. No. of BOQ	Description of Goods	Details of the location(s) at which the local value addition is made
10	GRINDING BALL, BOILER	
20	HOLLOW FILLER BALL, BOILER	
30	GRINDING RING, SAO-MO2-SM-A3K-728-2	

- 1.2 We undertake that a certificate from the statutory auditor or cost auditor (in the case the bidder is a company) or from a practicing cost accountant or practicing chartered accountant (in respect of bidders other than companies) certifying the percentage of local content shall be submitted by us prior to submission of our last bill for payment.##

## This para is applicable in packages with estimated value (excluding taxes & duties) exceeding INR 10 Crores.

- 2.0 Further, we hereby confirm that we are presently not debarred / banned by any other procuring entity for violation of ‘Public Procurement (Preference to Make In India), Order 2017’ (PPP-MII Order) dated 15.06.2017 and its subsequent revisions / amendments issued by Department of Industrial Policy and Promotion (DIPP).
- 3.0 We agree to furnish any information as a proof of the above to your satisfaction as and when required.

- Note : 1) Continuation sheets of like size and format, may be used as per Bidder's requirement and shall be annexed to this Attachment.
- 2) In case a Bidder has been banned/debarred by any other procuring entity for violation of ‘Public Procurement (Preference to Make In India), Order 2017’ (PPP- MII Order) dated 15.06.2017 and its subsequent revisions / amendments issued by Department of Industrial Policy and Promotion (DIPP), the same may be declared by Bidder by striking off para 2.0 above and declaring the details of banning using additional sheets which shall be annexed to this Attachment.

### III. QUALIFYING REQUIREMENT

The bidder who wishes to participate in the bidding shall meet the Qualifying Requirements stipulated hereunder:

#### **1.1 Technical Criteria:**

1.1.1 The Bidder should have been a regular manufacturer of E-type coal pulverisers and should have supplied such coal pulverisers to at least 2 coal fired units, each of 200MW or higher capacity and which are in successful operation prior to the date of Techno-Commercial bid opening.

**OR**

1.1.2 (a) The bidder should have been a manufacturer of “Ni hard / Hi chrome” castings with inhouse casting facilities with minimum annual manufacturing capacity of 90 MT and should have supplied at least {three Set of Grinding “Balls & Rings” ( Grinding Ring of Diameter 85 inches or more) OR “30 No’s of Grinding Balls & 6 No’s of Grinding Rings(Top/Bottom) having Grinding Ring Diameter 85 inches or more”} of “Ni Hard and/or Hi chrome” material used in Coal pulverisers during last seven (07) years prior to the date of techno-commercial bid opening.

**AND**

1.1.2 (b) The bidder should either himself or through a Company/Agency in which he has controlling stake, own following manufacturing and testing facilities for use by the bidder for manufacturing of the grinding balls. (Bidder to furnish proof of ownership/controlling stake of the facilities along with his bid).

#### **Manufacturing Facilities:**

- a) Induction / Cupola / Induction Arc Furnace (Single/Multiple) for melting iron 8.0 (Eight) Tones at a time.
- b) Machining facilities for machining grinding rings
- c) Heat treatment facility for grinding balls

#### **Testing Facilities:**

- a) Hardness testing
- b) Micro structure testing
- c) Chemical composition testing
- d) Ultrasonic testing machine
- e) Spectrometer/Spectrogram

**OR**

1.1.3 The bidder should be a manufacturer of “Grinding Ball(s) & Ring(s)” of “Ni Hard / Hi Chrome” material for Coal pulverisers and should have supplied at least {two Set of Grinding “Balls & Rings” ( Grinding Ring of Diameter 85 inches or more) OR “20 No’s of Grinding Balls & 4 No’s of Grinding Rings (Top/Bottom) having Grinding Ring Diameter 85 inches or more”} for coal pulverisers and should have an “ongoing collaboration / license agreement” with a manufacturer who meets the qualifying requirements as stipulated at Clause 1.1.2 (a) above. In such a case, bidder along with his collaborator shall furnish a Deed of Joint Undertaking (DJU) as per the format enclosed in the Bid documents for successful performance of the grinding rings offered by him. The joint deed(s) of undertaking shall be submitted along with the bid, failing which the bidder shall be disqualified and his bid shall be rejected. In case of award, the collaborator will be required to furnish on demand bank Guarantee for 1.5% of the total contract price in addition to the Contract Performance Securities to be furnished by the bidder. Further Bidder should have manufacturing and testing facilities as per 1.1.2(b) above.

1.1.4 The Bidder should have successfully executed supply of "E-type Coal pulverisers / Grinding elements for Coal pulverisers" within preceding seven (07) years prior to the date of Techno-Commercial bid opening, in any of the following manner:

**A. One (1) order having executed value not less than Rs. 379.0 Lakh**

**OR**

**B. Two (2) orders having executed value not less than Rs. 237.0 Lakh each**

**OR**

**C. Three (3) orders having executed value not less than Rs. 190.0 Lakh each**

**Notes for Technical Criteria:**

1. The word “Executed” mentioned above means that the bidder should have achieved the criteria specified above, even if the total contract is started earlier and/or is not completed/closed.
2. 1 SET of Grinding (Balls & Rings) consists of - 10 Nos’s of Grinding Balls & 02 No’s of Rings (Top & Bottom).

3. In case of orders under execution, the value of work executed prior to the date of Techno-Commercial bid opening duly certified by bidder's client shall be considered acceptable.
4. For arriving at the executed value of work specified above, basic amount only shall be considered. In case contract is inclusive of taxes, bidder should provide the break –up of basic value and taxes.

## **1.2 Financial Criteria:**

- 1.2.1 The Average Annual Turnover of the Bidder, should not be less than **Rs. 474 Lakh (Rupees Four Hundred & Seventy Four lakh only)** during the preceding three (3) completed financial years as on the date of Techno-Commercial bid opening.
- 1.2.2 In case the bidder does not satisfy the financial criteria, stipulated at Cl. 1.2.1 above on its own, its Holding Company would be required to meet the stipulated turnover requirements at Cl. 1.2.1 above, provided that the net worth of such Holding Company as on the last day of the preceding financial year is at least equal to or more than the paid-up share capital of the Holding Company. In such an event, the bidder would be required to furnish along with its Techno-Commercial bid, a Letter of Undertaking from the Holding Company, supported by Board Resolution, as per the format enclosed in the bid documents, pledging unconditional and irrevocable financial support for the execution of the Contract by the bidder in case of award.
- 1.2.3 In case the bidder is not able to furnish its audited financial statements on stand-alone entity basis, the unaudited unconsolidated financial statements of the bidder can be considered acceptable provided the bidder further furnishes the following documents for substantiation of its qualification.
  - Copies of the unaudited unconsolidated financial statements of the bidder along with copies of the Audited consolidated financial statements of its Holding Company.
  - A Certificate from the CEO/CFO of the Holding Company, as per the format enclosed in the bidding documents, stating that the unaudited unconsolidated financial statements form part of the Consolidated Annual Report of the company.
- 1.2.4 In cases where audited results for the last preceding financial year as on the date of Techno-Commercial bid opening are not available, the financial results certified by a practicing Chartered Accountant shall be considered acceptable. In case, Bidder is not able to submit the Certificate from practicing Chartered Accountant certifying its financial

parameters, the audited results of three consecutive financial years preceding the last financial year shall be considered for evaluating the financial parameters. Further, a Certificate would be required from the CEO/CFO as per the format enclosed in the bidding documents stating that the Financial results of the Company are under audit as on the date of Techno-Commercial bid opening and the Certificate from the practicing Chartered Accountant certifying the financial parameters is not available.

**Notes for 1.2:**

- i. Other income shall not be considered for arriving at annual turnover.
- ii. "Holding Company" and "Subsidiary Company" shall have the meaning ascribed to them as per Companies Act of India, in vogue.
- iii. Net worth means the sum total of the paid up share capital and free reserves. Free reserve means all reserves credited out of the profits and share premium account but does not include reserves credited out of the revaluation of the assets, write back of depreciation provision and amalgamation. Further, any debit balance of Profit and Loss account and miscellaneous expenses to the extent not adjusted or written off, if any, shall be reduced from reserves and surplus.

**IV. DOCUMENTS IN SUPPORT OF MEETING THE QUALIFYING REQUIREMENTS:**

The Bidder shall submit documents towards in support of meeting the QR stipulated in the Detailed NIT along with their bid (**ANNEXURE I**) which shall include:

- a) Company Registration certificate / certificate of incorporation/ Partnership agreement etc.
- b) Memorandum and Article of Association including changes in the constitution of the firm/company, name and address/(es) of Sole proprietor / partners / board of directors, partnership deed (up to date), if any, in case of partnership firm and affidavit for proprietorship concern.
- c) Copy of GST Registration document.
- d) Copies of the Letter of Award/Purchase orders/Contracts along with Certificate(s) from the Client(s) for successful execution of the assignment with value and period of executions in support of meeting the QR as stipulated in NIT.
- e) Copies of financial statement in support of meeting the QR as stipulated in NIT
- f) Any Other Document in support of meeting the QR as stipulated in the Detailed NIT

The bidder shall be required to submit duly certified and verified documents from their Statutory Auditors or specified Third Party Inspection Agency (TPIA) in support of meeting Technical QR along with a certificate regarding verification of authenticity of documents as per the format placed at **Annexure-II** (Undertaking from Statutory Auditor) and/ or **Annexure III** (Undertaking from TPIA). All the documents submitted by the bidder in support of meeting Technical QR shall be digitally signed by the Statutory Auditor and/ or specified TPIA”

Further, wherever information can be drawn from books of accounts, records and other relevant documents, Bidders can also submit a certificate issued by their Independent Statutory Auditor certifying the data required for meeting the Technical Qualification Requirements.

**Details of submitted copy of Purchase Orders/ Work Orders / Contract Agreements, Client Certificates etc.), duly certified and verified by statutory auditors or specified TPIA should be entered in Annexure I.**

In case documents are certified & verified for authenticity through TPIA, the verification and certification of authenticity of documents is acceptable from any of the following TPIAs:

- (1) Société Générale de Surveillance / SGS India Pvt. Ltd.(SGS)
- (2) Gulf Lloyds Industrial Services (India) Pvt. Ltd (GLISPL)
- (3) International Certification Services (ICS)
- (4) TUV Rheinland (India) Pvt. Ltd.
- (5) TÜV SÜD South Asia Pvt. Ltd.
- (6) TUV India Pvt. Ltd. (TÜV Nord Group)
- (7) Intertek India Pvt. Ltd.
- (8) Moody International (India) Pvt. Ltd.
- (9) RINA India Pvt. Ltd.
- (10) Competent Inspectorate and Consultants LLP

The following website may be referred for contact details of above ten (10) TPIAs:

[http://nabcb.qci.org.in/accreditation/reg\\_bod\\_inspection\\_bodies.php](http://nabcb.qci.org.in/accreditation/reg_bod_inspection_bodies.php)

**Any document pertaining to reference works/ plants in support of Technical QR, which is not certified by specified TPIA or Statutory Auditor of the bidder, as per the format enclosed with the bidding documents, shall not be considered verified/ certified for the purpose of evaluation, and the bid shall be liable for rejection.**

The Bidder shall be responsible to get their documents/ credentials in support of Qualifying Requirements verified & certified by their Statutory Auditor(s) and/ or specified TPIAs. All the costs pertaining to third party verification and certification (including those by statutory auditors) shall be borne by the Bidder. Employer shall have no liability (financial or otherwise) towards the same and shall not be liable for any claim/ dispute between the bidder and TPIA and/ or Statutory Auditor.

***Bidders are required to fill Annexure I/ IA properly. These references shall only be considered to ascertain the bidder's compliance to Qualifying Requirement (QR).***

## ANNEXURE I

### Summary of Details & Documents in support of QR

#### **Tender Reference/ NIT No:**

Bidders Name and Address:

To,  
GM(C&M)  
NTPC Limited, Central Procurement Group-I,  
NTPC WR-II office, Sector-24, Tuta,  
Naya Raipur, Chattisgarh - 492101 (India)

QR No.	QR Stipulation as in NIT	Meet (Yes/No)	Brief Description along with supporting documents
1.1	<b>Technical Criteria</b>		
	<p>1.1.1 The Bidder should have been a regular manufacturer of E-type coal pulverisers and should have supplied such coal pulverisers to at least 2 coal fired units, each of 200MW or higher capacity and which are in successful operation prior to the date of Techno-Commercial bid opening.</p> <p style="text-align: center;"><b>OR</b></p> <p>1.1.2 (a) The bidder should have been a manufacturer of “Ni hard / Hi chrome” castings with inhouse casting facilities with minimum annual manufacturing capacity of 90 MT and should have supplied at least {three Set of Grinding “Balls &amp; Rings” ( Grinding Ring of Diameter 85 inches or more) OR “30 No’s of Grinding Balls &amp; 6 No’s of Grinding Rings(Top/Bottom) having Grinding Ring Diameter 85 inches or more”} of “Ni Hard and/or Hi chrome” material used in Coal pulverisers during last seven (07) years prior to the date of</p>		



techno-commercial bid opening.

**AND**

1.1.2 (b) The bidder should either himself or through a Company/Agency in which he has controlling stake, own following manufacturing and testing facilities for use by the bidder for manufacturing of the grinding balls. (Bidder to furnish proof of ownership/controlling stake of the facilities along with his bid).

**Manufacturing Facilities:**

- a) Induction / Cupola / Induction Arc Furnace (Single/Multiple) for melting iron 8.0 (Eight) Tones at a time.
- b) Machining facilities for machining grinding rings
- c) Heat treatment facility for grinding balls

**Testing Facilities:**

- a) Hardness testing
- b) Micro structure testing
- c) Chemical composition testing
- d) Ultrasonic testing machine
- e) Spectrometer/Spectrogram

**OR**

1.1.3 The bidder should be a manufacturer of “Grinding Ball(s) & Ring(s)” of “Ni Hard / Hi Chrome” material for Coal pulverisers and should have supplied at least {two Set of Grinding “Balls & Rings” ( Grinding Ring of Diameter 85 inches or more) OR “20 No’s of Grinding Balls & 4 No’s of Grinding Rings (Top/Bottom) having Grinding Ring Diameter 85 inches or more”} for coal pulverisers and should have an “ongoing collaboration / license

agreement” with a manufacturer who meets the qualifying requirements as stipulated at Clause 1.1.2 (a) above. In such a case, bidder along with his collaborator shall furnish a Deed of Joint Undertaking (DJU) as per the format enclosed in the Bid documents for successful performance of the grinding rings offered by him. The joint deed(s) of undertaking shall be submitted along with the bid, failing which the bidder shall be disqualified and his bid shall be rejected. In case of award, the collaborator will be required to furnish on demand bank Guarantee for 1.5% of the total contract price in addition to the Contract Performance Securities to be furnished by the bidder. Further Bidder should have manufacturing and testing facilities as per 1.1.2(b) above.

1.1.4 The Bidder should have successfully executed supply of "E-type Coal pulverisers / Grinding elements for Coal pulverisers" within preceding seven (07) years prior to the date of Techno-Commercial bid opening, in any of the following manner:

**D. One (1) order having executed value not less than **Rs. 379.0 Lakh****

**OR**

**E. Two (2) orders having executed value not less than **Rs. 237.0 Lakh** each**

**OR**

	<p><b>F. Three (3) orders having executed value not less than <b>Rs. 190.0 Lakh</b> each</b></p> <p><b>Notes for Technical Criteria:</b></p> <ol style="list-style-type: none"> <li>1. The word “Executed” mentioned above means that the bidder should have achieved the criteria specified above, even if the total contract is started earlier and/or is not completed/closed.</li> <li>2. 1 SET of Grinding (Balls &amp; Rings) consists of - 10 Nos’s of Grinding Balls &amp; 02 No’s of Rings (Top &amp; Bottom).</li> <li>3. In case of orders under execution, the value of work executed prior to the date of Techno-Commercial bid opening duly certified by bidder’s client shall be considered acceptable.</li> <li>4. For arriving at the executed value of work specified above, basic amount only shall be considered. In case contract is inclusive of taxes, bidder should provide the break –up of basic value and taxes.</li> </ol>		
1.2	<b><u>Financial Criteria</u></b>	<b>Meet (Yes/No)</b>	<b>Brief Description along with supporting documents</b>
	<p>1.2.1 The Average Annual Turnover of the Bidder, should not be less than <b>Rs. 474 Lakh (Rupees Four Hundred &amp; Seventy Four lakh only)</b> during the preceding three (3) completed financial years as on the date of Techno-Commercial bid opening.</p> <p>1.2.2 In case the bidder does not satisfy the financial criteria, stipulated at Cl. 1.2.1</p>		

above on its own, its Holding Company would be required to meet the stipulated turnover requirements at Cl. 1.2.1 above, provided that the net worth of such Holding Company as on the last day of the preceding financial year is at least equal to or more than the paid-up share capital of the Holding Company. In such an event, the bidder would be required to furnish along with its Techno-Commercial bid, a Letter of Undertaking from the Holding Company, supported by Board Resolution, as per the format enclosed in the bid documents, pledging unconditional and irrevocable financial support for the execution of the Contract by the bidder in case of award.

1.2.3 In case the bidder is not able to furnish its audited financial statements on stand-alone entity basis, the unaudited unconsolidated financial statements of the bidder can be considered acceptable provided the bidder further furnishes the following documents for substantiation of its qualification.

- Copies of the unaudited unconsolidated financial statements of the bidder along with copies of the Audited consolidated financial statements of its Holding Company.
- A Certificate from the CEO/CFO of the Holding Company, as per the format enclosed in the bidding documents, stating that the unaudited unconsolidated financial statements

	form part of the Consolidated Annual Report of the company.		
<p>1.2.4 In cases where audited results for the last preceding financial year as on the date of Techno-Commercial bid opening are not available, the financial results certified by a practicing Chartered Accountant shall be considered acceptable. In case, Bidder is not able to submit the Certificate from practicing Chartered Accountant certifying its financial parameters, the audited results of three consecutive financial years preceding the last financial year shall be considered for evaluating the financial parameters. Further, a Certificate would be required from the CEO/CFO as per the format enclosed in the bidding documents stating that the Financial results of the Company are under audit as on the date of Techno-Commercial bid opening and the Certificate from the practicing Chartered Accountant certifying the financial parameters is not available.</p>	<b>Financial year</b>	<b>Turnover (Rs.)</b>	
	2020-21		
	2021-22		
	2022-23		
	2023-24		
Average Annual Turnover for the preceding three (03) completed financial years.			
<p><b>Notes for 1.2:</b></p> <ol style="list-style-type: none"> <li>1 Other income shall not be considered for arriving at annual turnover.</li> <li>2 “Holding Company” and “Subsidiary Company” shall have the meaning ascribed to them as per Companies Act of India, in vogue.</li> <li>3 Net worth means the sum total of the paid-up share capital and free reserves. Free reserve means all reserves credited out of the profits and share premium account but does not include reserves credited out of the revaluation of the assets, write back of depreciation provision and amalgamation. Further, any debit balance of Profit and Loss account and miscellaneous expenses to the extent not adjusted or written off, if any, shall be reduced from reserves and surplus.</li> </ol>			

**The Reference Plants/ Orders/ Works declared, shall only be considered for evaluation/ establishing compliance to Qualifying Requirements. No change or substitution in respect of reference Plants/ Orders for meeting the specified Qualifying requirements shall be offered by the Bidder.**

***The order-1 details are given below:***

SI No	Item Description	Details
(i)	Name of the Station and its location	
(ii)	Client Name and Address e-mail, Mobile and Tel. No	
(iii)	Name and designation of the responsible person in Client's organization	
(iv)	LOA No. & Date	
(iv)	Purchase Order / Contract No. & Date	
(v)	Value of PO (Basic value & taxes break up required)	
(vi)	Executed value of PO (Basic value & taxes break up required)	
	<i>In support of the above, we have attached Copies of relevant purchase orders along with proof of execution such as client certificate, corresponding invoice/ delivery challans, LR, E-way Bill/ installation/ performance report etc</i>	At Appendix no. ....to Annexure -IA.

***The order-2 details are given below:***

SI No	Item Description	Details
(i)	Name of the Station and its location	
(ii)	Client Name and Address e-mail, Mobile and Tel. No	
(iii)	Name and designation of the responsible person in Client's organization	
(iv)	LOA No. & Date	
(iv)	Purchase Order / Contract No. & Date	
(v)	Value of PO (Basic value & taxes break up required)	
(vi)	Executed value of PO (Basic value & taxes break up required)	
	<i>In support of the above, we have attached Copies of relevant purchase orders along with proof of execution such as client certificate, corresponding invoice/ delivery challans, LR, E-way Bill/ installation/ performance report etc</i>	At Appendix no. ....to Annexure -IA.

***The order-3 details are given below:***

SI No	Item Description	Details
(i)	Name of the Station and its location	
(ii)	Client Name and Address e-mail, Mobile and Tel. No	
(iii)	Name and designation of the responsible person in Client's organization	
(iv)	LOA No. & Date	
(iv)	Purchase Order / Contract No. & Date	
(v)	Value of PO (Basic value & taxes break up required)	
(vi)	Executed value of PO (Basic value & taxes break up required)	
	<i>In support of the above, we have attached Copies of relevant purchase orders along with proof of execution such as client certificate, corresponding invoice/ delivery challans, LR, E-way Bill/ installation/ performance report etc</i>	At Appendix no. ....to Annexure -IA.

**ANNEXURE IA**

**Bidders are required to fill Annexure I properly. These references shall only be considered to ascertain the bidder's compliance to Qualifying Requirement (QR).**

**Bidder's Qualifications**

(To be uploaded in Pre-Qual/Technical Cover/Envelope)

**Bidder to enclose supporting documents in support of meeting Qualifying Requirements in line with (NIT)**

**NAME OF BIDDER:**

**PAN NUMBER:**

**GST REGISTRATION NUMBER:**

**Details of Completed / Executed work :**

S.No.	WO No / Date	Executed Amount	Date of Execution/ Completion	Document Submitted		
				Name of Customer / Company, Phone, Fax, Email id & Name of contact person	Work order Copy with BOQ Yes /No	Document in support of executed work Completion Certificate / Copy of Measurement book(R/A bills) / Proof of receipt of payment etc.
1.						
2.						
3.						

**Notes:**

**The Reference Plants/ Orders/ Works declared, shall only be considered for evaluation/ establishing compliance to Qualifying Requirements. No change or substitution in respect of reference Plants/ Orders for meeting the specified Qualifying requirements shall be offered by the Bidder.**



(LIST OF FINANCIAL DOCUMENTS) ANNEXURE IB

Bidder's Name & Address:

To,  
NTPC Limited,

The following Documents are annexed to this attachment.

1. Annual reports for preceding three years as on the date of Techno-commercial Bid opening.

**ANNUAL TURNOVER FOR 03 FINANCIAL**

**YEARS :**

<b>2023-2024:</b>	<b>LAKHS (UDIN No.:</b>	<b>)</b>
<b>2022-2023:</b>	<b>LAKHS (UDIN No.:</b>	<b>)</b>
<b>2021-2022:</b>	<b>LAKHS (UDIN No.:</b>	<b>)</b>
<b>2020-2021:</b>	<b>LAKHS (UDIN No.:</b>	<b>)</b>

@ In case Bidder is not able to submit the Certificate from a practicing Chartered Accountant certifying its financial parameters for the last financial year, the audited results of the three consecutive financial years preceding the last financial year shall be considered for evaluating the financial parameters. Further, a Certificate would be required from the CEO/CFO as per the format enclosed in the bidding documents stating that the Financial results of the Company are under audit as on the date of Techno-commercial bid opening and the Certificate from the practicing Chartered Accountant certifying the financial parameters is not available.

Date : Signature.....  
Place : Name of Authorised person having Power of attorney.....  
Designation.....  
CommonSeal.....

**ANNEXURE IC**

**Proforma of Certificate from the CEO/CFO of the company in accordance with Financial requirement criteria in cases where audited results for the last financial year as on the date of Techno-commercial bid opening are not available**

(To be submitted by Bidder along with the Techno-commercial Bid with QR Documents)

Ref:

Date:

To

Dear Sir,

1.0 I, Mr./Ms. .... (\*CEO of the Company/\*CFO of the Company), confirm and undertake that the Financial results of the Company are under audit as on the date of Techno- commercial bid opening and the Certificate from the practicing Chartered Accountant certifying the financial parameters is not available.

2.0 Accordingly, the company is not able to submit the Certificate from a practicing Chartered Accountant certifying its financial parameters for the last financial year and the audited results of the three consecutive financial years preceding the last financial year have been considered for meeting the financial parameters in the bid submitted by M/s .....(Name of the Bidder) for the ..... (Name of the package) under NIT reference No. .... Dated .....

Yours faithfully,

Signature

Name & Designation.....  
Name of the Company.....

(Seal of Company).....

Note : \*Strike off whichever is not applicable.

**ANNEXURE II**

**Undertaking from Independent Statutory Auditor**

(On letter head digitally signed by a person duly authorized to Sign on behalf of the Statutory Auditor)

Bid Ref. No:

DATE:

To,

**GM (C&M)-CPG-1  
NTPC Limited, Western Region II Headquarters,  
Plot No-87, Sector-24, Atal Nagar,  
Naya Raipur, Raipur  
Chhatisgarh-492018**

**Subject: Authentication of veracity of documents submitted by M/s ..... in support of meeting the Qualifying Requirements**

Ref : IFB/Tender no. ....

Name of the Package/ Tender: .....

Dear Sir,

M/s. .... (hereinafter called Bidder) having Registered office at .....intend to participate in above referred tender of NTPC Ltd.

We, M/s ..... has been appointed as Statutory Auditor for the Bidder i.e. M/s ..... (Relevant documents on our appointment attached)

The tender condition stipulates that the bidder shall submit supporting Documents pertaining to Technical Qualifying Requirement duly verified and certified by Statutory Auditor.

In this regard, it is hereby confirmed that we have examined the following documents, which are also attached with this letter. The same has been verified from the Original Documents and/ or Client for authenticity.

We hereby confirm that the following documents are found to be genuine and authentic.

1. Doc ref./PO No. no. .... dated. (name of Documents)

2. Doc ref. no./PO No. .... dated..(name of Documents)

3. ....

The Executed Value/ Quantity of the PO(s) as above has been verified using invoice copy(s)/ LR Bill and completion certificate/ inspection report/ material despatch clearance certificate submitted as execution proof and are found to be genuine and authentic:

1. Invoice no. .... dated / LR Bill ..... dated and completion certificate ..... dated  
(name of Documents)

2. Invoice no. .... dated / LR Bill ..... dated and completion certificate ..... dated  
(name of Documents)

3. ....

**All the aforesaid documents have been digitally signed by us as a certificate of authenticity.**

\*Further, we have examined the books of accounts, records, and other relevant documents, along with other necessary information and explanations furnished by M/s. \_\_\_\_\_(bidder) and hereby certify following:

.....

This certificate is issued at the request of M/s ..... (Bidder) for the purpose of participating in tender/s.

Thanking you,

.....

**Annexure III**

**Undertaking from Third Party Inspection Agency**

(on letter head digitally signed by a person duly authorized to Sign on behalf of the TPIA)

Ref.: \_\_\_\_\_ Date: \_\_\_\_\_

To,

**GM (C&M)-CPG-1  
NTPC Limited, Western Region II Headquarters,  
Plot No-87, Sector-24, Atal Nagar,  
Naya Raipur, Raipur  
Chhatisgarh-492018**

Dear Sir,

**Subject: Authentication of veracity of documents submitted by M/s.....in  
support of meeting the Qualifying Requirements**

Ref: IFB/Tender no. ....

Name of the Package/ Tender: .....

M/s. .... (hereinafter called Bidder) having Registered office at.....  
intend to participate in above referred tender of NTPC Ltd.

The tender condition stipulates that the bidder shall submit supporting Documents pertaining to Qualifying Requirement duly verified and certified by a specified independent Third Party Inspection Agency as per the list mentioned in the bidding documents.

In this regard, it is hereby confirmed that we have examined the following documents, which are also attached with this letter. The same has been verified from the Original Documents and / or Client for authenticity.

We hereby confirm that the following documents are found to be genuine and authentic.

1. Doc ref. no./PO No. .... dated.(name of Documents)
2. Doc ref. no./P O N o . .... dated (name of Documents)
3. ....

The Executed Value/ Quantity of the PO(s) as above has been verified using invoice copy(s)/ LR Bill and completion certificate/ inspection report/ material despatch clearance certificate submitted as execution proof and are found to be genuine and authentic:

1. Invoice no. .... dated / LR Bill ..... dated and completion certificate ..... dated (name of Documents)
2. Invoice no. .... dated / LR Bill ..... dated and completion certificate ..... dated (name of Documents)
3. ....

**All the aforesaid documents has been digitally signed by us as a certificate of authenticity.**

We further confirm that we neither have any vested interest in aforesaid tender nor have any conflict of interest in respect of above tender.

This certificate is issued at the request of M/s ..... (Bidder) for the purpose of participating in the subject tender/s.

Thanking you,

.....

*\* Strike off, whichever is not applicable.*

## V. **EARNEST MONEY DEPOSIT (EMD) / BID SECURITY**

The Earnest Money Deposit (EMD) shall in the form of Bank Guarantee from banks specified in the published GeM bid.

**The format of Bid Guarantee (BG) towards EMD shall be as per attached format (Form -1) and should be submitted from a bank as indicated in Form – 3.**

MSE Bidders who are manufacturer of the tendered Items and have a valid Udyam Registration Certificate shall be exempted from submission of EMD.

The BG towards EMD shall remain valid for a period of forty-five (45) days beyond the original Bid validity period or beyond any extension in the period of Bid validity subsequently requested.

**Bidders shall be required to upload the scanned copy of the BG on GeM portal.**

**Bidder shall also be required to submit the Original BG in physical form to reach NTPC at the address mentioned in Bidding Documents, not later than 5 days from the date of submission of Techno-Commercial bids or before the Price Bid opening, whichever is earlier, failing which its bid shall be rejected and not considered for further evaluation.**

**Sealed envelope containing EMD and any offline documents sought in tender, must be marked and details like NIT/ Tender No, Scope of Work, Bid Opening Due Date etc mentioned on the envelope**

### **CONFIRMATION OF BGS**

While issuing the physical BGs, the Bidder's Bank shall also send electronic message through secure SFMS (in case of BGs issued from within India) or SWIFT (in case of BGs issued from outside India) to Employer's Beneficiary Bank whose details are provided above

i	Bank Name	ICICI BANK LTD.
ii	Branch	CONNAUGHT PLACE BRANCH
iii	Bank address	9A, PHELPS BUILDING, INNER CIRCLE, NEW DELHI-110001
iv	IFSC Code	ICIC0000007

BG issuing/amending bank must send the BG advice in the form of message format via SFMS (Structured Financial Messaging System) as provided by RBI. The format of the message for confirmation of the BG shall be as below:

BG advising message: IFN 760COV/ IFN 767COV via SFMS

Field Number: Particulars (to be mentioned in Row 1)

7037: NTPCBG (unique identifier)

## **EMD Exemption for MSE Bidders**

MSE Bidders who are manufacturer of the tendered Items and have a valid Udyam Registration Certificate shall be exempted from submission of EMD.

In case of an upward change in terms of investment in plant and machinery or equipment or turnover or both, and consequent re-classification, an enterprise shall continue to avail of all non-tax benefits of the category (micro or small or medium) it was in before the re-classification, for a period of three years from the date of such upward change.

For availing MSE benefits, bidder must confirm that items quoted by the bidder are manufactured by them.

In support of above claim regarding manufacturing of each of the specified Item(s), Bidder will furnish necessary details of Stores/ Category of items etc. as mentioned in the MSE registration certificate along with the Undertaking as given at Annexure IV. In case, such details are not available in the Registration Certificate furnished by the Bidder for any of the quoted item(s), other relevant details/documentary evidence will be furnished along with the Undertaking in support of the claim that such item(s) are manufactured by the Bidder.

Except Udyam Registration Certificate no other registration documents will be considered for MSEs exemption & benefits for bids which will be under evaluation stage on 1st January 2022 onwards.

The benefit as above to MSEs shall be available only for Goods/ Services produced & provided by MSEs. As per answer to FAQ no. 18 circulated vide Office Memorandum F. No. 22(1)/2012-MA dated 24.10.2016 "Policy is meant for procurement of goods produced and services rendered by MSEs. However, traders are excluded from the purview of benefits and exemption of MSEs."



**Undertaking to be given by the MSE Bidder for availing benefits/  
exemptions as per PPP 2012 for cases**

M/s NTPC Limited

Ref: Our Bid Reference Number: \_\_\_\_\_ Dated \_\_\_\_\_ against

Tender Invitation Number \_\_\_\_\_ Dated \_\_\_\_\_ for \_\_\_\_\_

Name of Package \_\_\_\_\_

With reference to our bid (as referred above) against subject Tender Invitation, we have attached relevant documents for availing benefits/ exemptions available to MSEs as per PPP 2012 and its subsequent amendments, if any. We are aware that benefits to MSEs under PPP 2012 are available to manufacturer of goods and not to traders/dealers and accordingly, we hereby undertake that:

*We are **manufacturer of the quoted item(s)** and understand that the benefits as applicable to MSEs under PPP 2012 including Purchase Preference shall be applicable as per provisions of Bidding Document for all the quoted items of our bid.*

We also understand that in case documents submitted by us for availing benefits/exemptions applicable to MSEs under PPP 2012 are not found to be in order by NTPC Limited/ Employer at any stage of Bid Evaluation and EMD and/or cost of Bid Documents (wherever applicable) have also not been submitted by us then our bid shall not be considered further for evaluation and be rejected.

Thanking you,

(Authorized Signatory)

Name & address of the bidder \_\_\_\_\_

Date:

**\* Strike out which is not applicable**

## **VI. COMPLIANT BID:**

No deviation, whatsoever, is permitted by EMPLOYER to any provision of Bidding Documents. The Bidders are advised that while making their Bids and quoting prices, all conditions are appropriately taken into consideration.

Bidders shall certify their compliance to the complete Bidding Documents as per Certificate at **Annexure V** of the Tender:

In case the Products and/or Services offered do not meet the Technical requirements, the bid shall be rejected as Technically non-responsive.

Bidders may note that in case the Bidder refuses to withdraw additional conditions/ deviations/ variations/ exception, implicit or explicit, found anywhere in the techno-commercial bid, the bid shall be rejected as Technically non-responsive.

Bidders may also note that any deviation/variation in any form in the Price Bid shall result in forfeiture of EMD.

**CERTIFICATE FOR COMPLIANCE  
TO  
ALL PROVISIONS OF BIDDING DOCUMENTS  
(Certificate of "NIL" Deviation)  
Towards COMPLIANT BID**

**To,  
GM (C&M)-CPG-1  
NTPC Limited, Western Region II Headquarters,  
Plot No-87, Sector-24, Atal Nagar,  
Naya Raipur, Raipur  
Chhatisgarh-492018**

Dear Sir,

1. With reference to our Bid submitted against the tender, we hereby confirm that we comply with all terms, conditions and specifications of the Bidding Documents read in conjunction with Amendment(s) / Clarification(s) / Addenda/Errata (if any) issued by the Employer prior to opening of Techno-Commercial Bids and the same has been taken into consideration while making our Techno-Commercial Bid & Price Bid and we declare that we have not taken any deviation in this regard.

2. We understand that in case the Products and/or Services offered do not meet the Technical requirements, then our bid shall be rejected as Technically nonresponsive.

We also confirm that in case we refuse to withdraw additional conditions/deviations/exceptions/exception, implicit or explicit, found anywhere in the techno-commercial bid, our bid shall be rejected as Technically non-responsive.

We further confirm that if any deviation/variation in any form is found in our Price Bid, the EMD shall be forfeited.

(Authorised Signatory)

Name & address of the bidder .....

.....

Date:

## **VII. IMPORTANT INFORMATION FOR BIDDERS**

### **a. Fraud Prevention Policy**

NTPC has in place a policy for Prevention of Fraud. The “Fraud Prevention Policy” has been framed to provide a system for detection and prevention of fraud, reporting of any fraud that is detected or suspected and fair dealing of matters pertaining to fraud.

Fraud Prevention Policy shall mean the policy related to prevention of fraud displayed on NTPC tender website <https://ntpctender.ntpc.co.in> and <https://vendor.ntpc.co.in>

The Bidder along with its associate/collaborators/subcontractors/sub-vendors/ consultants/ service providers shall strictly adhere to the Fraud Prevention Policy of EMPLOYER displayed on its tender website <https://ntpctender.ntpc.co.in> and <https://vendor.ntpc.co.in> and shall immediately apprise Employer about any fraud or suspected fraud as soon as it comes to their notice. Bidders shall certify their compliance to the Fraud Prevention Policy as per Certificate at **Annexure VI**.

If in terms of above policy, it is established that the bidder/his representatives have committed any fraud while competing for this contract then the Earnest Money Deposit shall be forfeited.

### **b. Policy for Debarment from Business Dealings**

The Employer has in place a policy for withholding and banning of business Dealings and same is displayed on its tender website <https://ntpctender.ntpc.co.in> and <https://vendor.ntpc.co.in>. Business dealings may be withheld or banned with the Bidder/Contractor on account of any default by the contractor for any of the grounds detailed in the said Banning Policy.

NTPC reserves its right to withhold or ban or suspend business dealings with any Agency, if such Agency is found to have committed misconduct or any of its action(s) fall into any such categories as laid down in its Policy for Debarment from Business Dealings

Policy for Debarment from Business Dealings shall mean the policy related to Withholding & Banning of Business Dealings displayed on NTPC tender website <https://ntpctender.ntpc.co.in> and <https://vendor.ntpc.co.in>

Bidders shall submit the Declaration on Policy of for withholding and banning of Business Dealings Employer as per Certificate at **Annexure VII**

### **c. Anti-Bribery and Anti-Corruption (ABAC) Policy:**

Anti-Bribery and Anti-Corruption (ABAC) Policy: The Bidder and its employees along with its Associate/ Collaborator/ Sub- Contractors / Sub-Vendors / Consultants / Service Providers and all other persons associated with business of Employer shall strictly adhere to Anti- Bribery and Anti-Corruption (ABAC) Policy of Employer displayed on tender website <https://ntpctender.ntpc.co.in>.

Please refer and submit Adherence to Employer’s Anti-Bribery and Anti-Corruption (ABAC) Policy as per format attached as **Annexure VIII**.

### **d. One Bid per Bidder:**

Please refer Clause 29 of GeM GTC.

Please refer and submit the DECLARATION W.R.T. SINGLE BID Policy as per format attached as **Annexure IX**.

**e. Conflict of Interest**

A bidder shall not have conflict of interest with other bidders. Such conflict of interest can lead to anti-competitive practices to the detriment of Employer's interests. A bidder may be considered to have a conflict of interest with one or more parties in this bidding process, if:

- a) they directly or indirectly control, or are controlled by or are under common control of another entity; or
- b) they have the same legal representative/agent for purposes of their bids; or
- c) they have relationship with each other, directly or through common third party(ies), that puts them in a position to have access to information about or influence on the bid of another Bidder; or
- d) Bidder and/or any of its allied entity(ies), which directly or indirectly control(s) or is(are) controlled by or is(are) under common control of another entity, has(ve) participated as a consultant in the preparation of the design or technical specifications of the contract that is the subject of the tender; or
- e) Bidder participates in more than one bid in this bidding process.
- f) In cases of agents quoting on behalf of their principal manufacturers/service providers, one agent cannot represent two manufacturers/service providers or quote on their behalf in a particular tender enquiry. One manufacturer/service provider can also authorize only one agent. There can be only one bid from the following:
  - i) The principal manufacturer/service provider directly or through one Indian agent on his behalf; and
  - ii) Indian/foreign agent on behalf of only one principal.

For the purposes of this clause the term 'control' shall have the following meaning:

"Control" shall include the right to appoint majority of the directors or to control the management or policy decisions exercisable by a person or persons acting individually or in concert, directly or indirectly, including by virtue of their shareholding or management rights or shareholders' agreements or voting agreements or in any other manner.

Note: If two or more CPSEs/State PSEs participate in a tender, they will not be deemed to fall under the 'Conflict of Interest' provisions solely because they are under common control of Government of India / State Government.

Bidders shall certify their compliance to "Conflict of Interest" by submitting the DECLARATION W.R.T. CONFLICT OF INTERST as per format attached as **Annexure X**.

**Annexure-VI**

**FORM OF ACCEPTANCE OF FRAUD PREVENTION POLICY**

To,

**GM (C&M)-CPG-1  
NTPC Limited, Western Region II Headquarters,  
Plot No-87, Sector-24, Atal Nagar,  
Naya Raipur, Raipur  
Chhatisgarh-492018**

Dear Sir,

We have read the contents of the Fraud Prevention Policy of NTPC displayed on its tender website <https://ntpctender.ntpc.co.in> and <https://vendor.ntpc.co.in> and undertake that we along with our associate / collaborator / sub\_contractors / sub-vendors / consultants / service providers shall strictly abide by the provisions of the Fraud Prevention policy of NTPC.

(Authorised Signatory)

Name & address of the bidder .....

.....

Date:

**Annexure-VII**

**DECLARATION ON BANNING POLICY**

To,  
**GM (C&M)-CPG-1**  
**NTPC Limited, Western Region II Headquarters,**  
**Plot No-87, Sector-24, Atal Nagar,**  
**Naya Raipur, Raipur**  
**Chhatisgarh-492018**

Dear Sir,

1) We have read the contents of the Banning Policy of NTPC displayed on its tender website <https://ntpctender.ntpc.co.in> and <https://vendor.ntpc.co.in> and agree to abide by this policy. Further, in terms of requirement under Banning policy we hereby declare the following:

- a) We have not been Banned/Blacklisted as on date of submission of bid by Ministry of Power or Government of India.
- b) We have not employed any public servant dismissed/removed or person convicted for an offence involving corruption or abetment of such offences.
- c) Our Director(s)/Owner(s)/Proprietor/Partner(s) have not been convicted by any court of law for offences involving corrupt and fraudulent practices including moral turpitude in relation to business dealings with Government of India or NTPC or NTPC's group companies during the last five years.

2) We further declare as under:

that if at any point subsequent to award of Contract, the declarations given above are found to be incorrect, NTPC Limited shall have the full right to terminate the Contract and take any action as per applicable laws for breach of contract including forfeiture of Bid Security/Performance Bank Guarantee.

(Authorised Signatory)

Name & address of the bidder .....

.....

Date:

**Annexure VIII**

**PACKAGE NAME:** .....

**BIDDING DOCUMENT NO:** . .....

**(Adherence to Employer’s Anti-Bribery and Anti-Corruption (ABAC) Policy)**

We and our employees along with our associate / collaborator/ subcontractors / sub vendors / consultants / service providers shall strictly abide by ‘Anti-Bribery and Anti-Corruption (ABAC) Policy’ of Employer as displayed on tender website at <https://ntpctender.ntpc.co.in/> under section ‘policy docs’ and undertake that we represent and confirm that we are aware of, understand, and will comply with all applicable laws and regulations relating to anti-corruption and anti-bribery and the ABAC Policy of Employer. In addition, each Party agrees that so long as it is conducting business with the other Party or the other Party’s affiliates, it will not, directly or indirectly, on behalf of the other Party or the other Party’s affiliates promise, offer, solicit, authorize, give or receive bribe, or other corrupt payment, item or service of value, or any other corrupt advantage, whether in cash or in kind, in relation to the participation in the tender.

(Authorised Signatory)

Name & address of the bidder .....

.....Date:



**Annexure IX**

**DECLARATION W.R.T. SINGLE BID**

To,

**GM (C&M)-CPG-1  
NTPC Limited, Western Region II Headquarters,  
Plot No-87, Sector-24, Atal Nagar,  
Naya Raipur, Raipur  
Chhatisgarh-492018**

Dear Sir,

We have read the contents of the Clause 29 of GeM GTC (One Bid per Bidder).

**In pursuant to Clause 29 of GeM GTC (One Bid per Bidder) following is declared:**

1. We have not made any other bid or multiple bids as understood or deemed in terms of this clause.
2. Sister/ Associated/ Allied concern having one or more common persons as Director/ Partner/ Member/ Owner have not participated in this tender.

It is also understood that if at any point of time the above declaration is found wrong, NTPC Limited shall have the full right to reject the bid, forfeit Bid Security and take any administrative/ legal actions.

(Authorised Signatory)

Name & address of the bidder .....

.....Date:

**ANNEXURE-X**

..... PACKAGE FOR.....  
PROJECT BIDDING DOCUMENT NO. ....

**(Compliance to “Conflict of Interest” provisions)**

We confirm that we have read and understood the Clause regarding “**Conflict of Interest**” and our bid is in compliance to this clause.

In case it is established that we have provided any false information in pursuance of the aforesaid Clause, while competing for this contract, then our bid shall be rejected and bid security shall be forfeited.

We also understand that in case we become successful bidder, if it is established that we have not complied with terms of aforesaid Clause, during execution of contract, this would be considered as fraudulent practice as mentioned in para 5.1 (j) of “Policy for Debarment from Business Dealings” and shall be dealt accordingly.

**VIII. Documents to be submitted along with the bid:**

1. EMD BG/ EMD Exemption Document
2. Declaration of Local content (**Annexure A**)
3. DOCUMENTS IN SUPPORT OF MEETING THE QUALIFYING REQUIREMENTS **along with Annexure I, IA, IB and IC.**
4. Undertaking from Independent Statutory Auditor/ Undertaking from Third Party Inspection Agency (**Annexure II/ III**)
5. Undertaking to be given by the MSE Bidder (**Annexure IV**) (applicable for MSE Bidders only)
6. CERTIFICATE FOR COMPLIANCE TO ALL PROVISIONS OF BIDDING DOCUMENTS (**Annexure V**)
7. FORM OF ACCEPTANCE OF FRAUD PREVENTION POLICY DOCUMENTS (**Annexure VI**)
8. DECLARATION ON BANNING POLICY DOCUMENTS (**Annexure VII**)
9. Undertaking for Adherence to Employer's Anti-Bribery and Anti-Corruption (ABAC) Policy (**Annexure VIII**)
10. DECLARATION W.R.T SINGLE BID (**Annexure IX**)
11. Undertaking for Compliance to "Conflict of Interest" provisions (**Annexure X**)

# **FORMS & FORMATS**

PROFORMA OF BANK GUARANTEE FOR EARNEST MONEY DEPOSIT/ BID SECURITY  
(To be stamped in accordance with Stamp Act)

Bank Guarantee No.....

Date :

To,

NTPC Limited,

.....

.....

Dear Sirs,

In accordance with your NIT No.....dated.....M/s  
..... (\*\*)...... having its registered/Head Office at  
.....  
.....(hereinafter called the 'Bidder') wish to participate in the said Bid for  
.....  
(name of package).

As an irrevocable Bank Guarantee against Earnest Money Deposit/Bid Security for an amount of ..... (\*) ..... valid for .....@..... days from ..... (\*\*\*)....., is required to be submitted by the Bidder as a condition precedent for participation in the said bid, which amount is liable to be forfeited on the happening of any contingencies mentioned in the Bidding Documents.

We, the ..... [Name and address of the Bank].....having our head office at ..... (#) ..... guarantee and undertake to pay immediately on demand by NTPC Ltd. (hereinafter called 'the Employer') the amount ..... (\*) (in figures and words) without any reservation, protest, demand and recourse. Any such demand made by the said 'Employer' shall be conclusive and binding on us irrespective of any dispute or difference raised by the Bidder.

This guarantee shall be irrevocable and shall remain valid up to ..... (@) If any further extension of this guarantee is required, the same shall be extended to such required

period (not exceeding one year) on receiving instructions from.....  
[Bidders name].....on whose behalf guarantee is issued.

In witness whereof the Bank, through its authorized officer has set its hand and stamp on this ..... Day .....20..... at .....

Signature.....

Name.....

Designation.....

Bank's Common Seal.....

Power of Attorney No.....

**Note:**

1. (\*) The amount shall be as specified in the NIT/Bidding Documents.  
(\*\*) Write the name and address of the Bidder  
(\*\*\*) This shall be the date of opening of bids.  
(#) Complete mailing address of the Head Office of the Bank to be given.  
(@) This date shall be forty five days beyond the validity of bid.
2. The Bank Guarantee shall be from a bank as per provisions of bidding documents.
3. The Stamp Paper of appropriate value shall be as per stamp act purchased in the name of the Bidder/Bank issuing the guarantee.
4. While getting the Bank Guarantee issued, Bidders are required to ensure compliance to the points mentioned in the Bank Guarantee Verification Check List in the bidding documents. Bidders are required to fill up this check List and enclose the same alongwith the Bank Guarantee.
5. The details of secure SFMS (in case of BGs issued from within India) or SWIFT (in case of BGs issued from outside India) sent by Bidder's Bank to Employer's Beneficiary Bank details of which are given in SPC must be furnished with the BG.

**BANK GUARANTEE VERIFICATION CHECKLIST**

Sl. No.	Details of Checks	Yes/ No
1	Is the BG on Non-judicial stamp paper/ e-stamp paper of appropriate value, as per Stamp Act ?	
2	Whether date, purpose of purchase of stamp paper and name of the purchaser are indicated on the stamp paper?  (The date of purchase of stamp paper should be of any date on or before the date of execution of BG and the stamp paper should be purchased either in the name of the executing Bank or the Bidder on whose behalf the BG has been issued. The stamp paper (other than e-stamp paper) should be duly signed by the stamp vendor).	
3	In case of BGs from Banks abroad, has the BG been executed on Letter Head of the Bank?	
4	Has the executing officer of BG indicated his name, designation and Power of Attorney No./ Signing Power No. etc. on the BG?	
5	Is each page of BG duly signed/ initialed by executant and whether stamp of Bank is affixed thereon? Whether the last page is signed with full particulars under seal of Bank as required in the prescribed proforma?	
6	Does the Bank Guarantee compare verbatim with the Proforma prescribed in the Bid Documents?	
7	Are the factual details such as Bidding Documents No./ Specification No., Amount of BG, validity of BG correctly mentioned in the BG?	
8	Whether overwriting/ cutting, if any on the BG have been properly authenticated under signature & seal of executant?	
9	Whether BG has been issued by a Bank in line with the provisions of Bidding Documents?	
10	In case BG has been issued by a Bank other than those specified in Bidding Document, is the BG confirmed by a Bank in India acceptable as per Bidding Document?	

Date :  
Place :

Name of Authorised Person  
Designation

**BANKS FROM WHICH BANK GUARANTEES FOR ADVANCE / SECURITY  
DEPOSIT TO BE FURNISHED BY BIDDER /CONTRACTOR CAN BE  
ACCEPTED**

**UPDATED SCHEDULED COMMERCIAL BANK LIST**

**A. STATE BANK OF INDIA**

**B. NATIONALISED BANKS**

- |                          |                         |
|--------------------------|-------------------------|
| 1. Bank of Baroda        | 7. Indian Bank          |
| 2. Bank of India         | 8. Punjab National Bank |
| 3. Bank of Maharashtra   | 9. Union Bank of India  |
| 4. Canara Bank           | 10. Punjab & Sind Bank  |
| 5. Central Bank of India | 11. UCO Bank            |
| 6. Indian Overseas Bank  |                         |

**C. SCHEDULED PRIVATE BANKS (INDIAN BANKS)**

- |                             |                                  |
|-----------------------------|----------------------------------|
| 1. Axis Bank Ltd            | 12. Jammu & Kashmir Bank Ltd     |
| 2. Bandhan Bank Limited     | 13. Karnataka Bank Ltd           |
| 3. CSB Bank                 | 14. Karur Vysya Bank Ltd         |
| 4. City Union Bank          | 15. Kotak Mahindra Bank          |
| 5. DCB Bank Ltd             | 16. Lakshmi Vilas Bank Ltd       |
| 6. Dhanlaxmi Bank Ltd       | 17. Nainital Bank Ltd            |
| 7. Federal Bank Ltd         | 18. RBL Bank Limited             |
| 8. HDFC Bank Ltd            | 19. South Indian Bank Ltd        |
| 9. ICICI Bank Ltd           | 20. Tamilnad Mercantile Bank Ltd |
| 10. IndusInd Bank Ltd       | 21. Yes Bank Ltd                 |
| 11. IDFC FIRST Bank Limited | 22. IDBI Bank Ltd.               |

**D. SCHEDULED PRIVATE BANKS (FOREIGN BANKS)**

- 1 AB Bank Ltd
- 2 Abu Dhabi Commercial Bank PJSC
- 3 American Express Banking Corporation
- 4 Australia & Newzealand Banking Group Limited
- 5 Barclays Bank Plc
- 6 Bank of America
- 7 Bank of Bahrain & Kuwait B.S.C.
- 8 Bank of Ceylon
- 9 Bank of China Limited
- 10 Bank of Nova Scotia
- 11 BNP Paribas
- 12 Citi Bank NA
- 13 Cooperatieve Rabobank UA
- 14 Crédit Agricole Corporate and Investment Bank



- 15 Credit Suisse AG
- 16 CTBC Bank Co Ltd
- 17 DBS Bank India Ltd
- 18 Deutsche Bank A.G.
- 19 Doha Bank Q.P.S.C
- 20 Emirates NBD Bank (PJSC)
- 21 First Abu Dhabi Bank PJSC
- 22 FirstRand Bank Ltd
- 23 HSBC Ltd
- 24 Industrial & Commercial Bank of China Ltd
- 25 Industrial Bank of Korea
- 26 JP Morgan Chase Bank, National Association
- 27 JSC VTB Bank
- 28 KEB Hana Bank
- 29 Kookmin Bank
- 30 Krung Thai Bank Public Company Ltd
- 31 Mashreq Bank PSC
- 32 Mizuho Bank Ltd
- 33 MUFG Bank, Ltd
- 34 NatWest Markets Plc
- 35 PT Bank Maybank Indonesia TBK
- 36 Qatar National Bank (Q.P.S.C.)
- 37 Sberbank
- 38 SBM Bank (India) Ltd
- 39 Shinhan Bank
- 40 Societe Generale
- 41 Sonali Bank Ltd
- 42 Standard Chartered Bank
- 43 Sumitomo Mitsui Banking Corporation
- 44 United Overseas Bank Ltd
- 45 Westpac Banking Corporation
- 46 Woori Bank

**\*Note - Any Addition/ Deletion/ Modification in Bank list shall be as per changes in Second Schedule List by RBI from time to time.**

**\*In case, Bank Guarantee is getting issued from State Bank of India, Bidder to take note of NTPC letter ref. NTPC/FC/CS/BG/01 dated 03.09.2014 and SBI letter ref. CAG-I/AMT-1/2014-15/370 dated 04.09.2014 attached herewith.\*In case, Bank Guarantee is getting issued from State Bank of India, Bidder to take note of NTPC letter ref. NTPC/FC/CS/BG/01 dated 03.09.2014 and SBI letter ref. CAG-I/AMT-1/2014-15/370 dated 04.09.2014 attached herewith.**



भारतीय स्टेट बैंक  
State Bank of India

कॉरपोरेट लेखा समूह शाखा, जवाहर व्यापार भवन,  
11-12 वां तल, 1, टॉलस्टोय मार्ग, नई दिल्ली-110 001  
Corporate Accounts Group Branch, Jawahar Vyapar Bhawan,  
11th & 12th Floor, 1, Tolstoy Marg, New Delhi-110 001

Tel.: 23374525, 23374505, 23374541 (AMT-1), 23353022 (DGM & COO), 23701043, 23359506 (A & A), 23352995 (CS), 23352968 (IB)  
Fax: 23353101 (Sec'tt.), 23352793 (CS), 23353029 (IB)

Shri K.P. Gupta,  
General Manager (Finance),  
NTPC Limited  
Scope Complex, 7, Institutional Area,  
Lodhi Road,  
New Delhi: 110 003.

CAG-II/AMT-1/2014-15/370

04.09.2014

Dear Sir,

**Format of the Bank Guarantee (BG) issued by State Bank of India**

We refer to your letter dated 3<sup>rd</sup> September 2014 wherein you have requested for excluding bidders/vendors of NTPC from insertion of additional Clause restraining assignment/transferability of BG.

Looking at our relationship with NTPC, as a very special case, we have since obtained waiver from our Authorities for excluding NTPC from insertion of the referred clause for BGs issued in your favour.

We are taking steps to issue suitable instructions to our offices for exclusion of this clause for BGs issued in favour of NTPC. In case any bidder or vendor submits to you a Bank Guarantee issued by any of our Branches containing the additional clause as mentioned above, request you to please bring it to our notice and advise us so that we can take-up with the concerned Branch for excluding it.

This is for your information and necessary action please.

Yours faithfully,

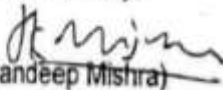
  
(Sandeep Mishra)

Deputy General Manager &  
Relationship Manager, AMT-1



एन टी पी सी लिमिटेड  
(भारत सरकार का उद्यम)

**NTPC Limited**  
(A Govt. of India Enterprise)

केन्द्रीय कार्यालय/Corporate Centre

Date : 03<sup>rd</sup> September 2014

Ref. No.: NTPC/FC/CS/BG/01  
Deputy General Manager,  
State Bank of India,  
CAG Branch,  
12 th floor, Jawahar Vyapar Bhavan, 1, Tolstoy Marg,  
New Delhi 110 001

Kind Atten: Sh. Sandeep Mishra

Sub: Format of the Bank Guarantee (BG) issued by State Bank of India – reg.

Dear Sir,

NTPC Limited is India's largest Power Company and a 'Maharatna PSU' with a significant presence in the entire value chain of power generation business. The procurement process of NTPC requires its participating Bidders to submit Bank Guarantees (BGs) as Bid security/other securities in a fixed format provided by NTPC.

It has been observed recently that BGs issued by various branches of State Bank of India are inserting the following additional clause.

QUOTE

*Notwithstanding anything contrary contained in any law for the time being in force or banking practice, this guarantee shall not be assignable or transferable by the beneficiary. Notice or invocation by any person such as assignee, transferee or agent of beneficiary shall not be entertained by the bank. Any invocation of guarantee can be made only by the beneficiary directly.*

UNQUOTE

The inclusion of the aforesaid clause in the BGs restricts the rights of NTPC under the BG and it may not be possible for NTPC to accept the aforesaid clause in the BGs submitted to us by our Bidders. It may also be mentioned that incorporation of the above additional clause in the BG results in the BG being returned by NTPC and consequently rejection of the bids of parties that have submitted such BGs.

In view of the above, it is requested that please take up at appropriate levels so that suitable instructions are issued to all your branches not to incorporate any such additional clause and henceforth BGs may be issued strictly as per NTPC format only.

Kindly acknowledge the receipt of this letter

Yours faithfully,

(K.P.Gupta)

General Manager (Finance)

Copy for Kind information: ED(CC&M) for kind info + n.s

एन टी पी सी लिमिटेड का कार्यालय, 7, इन्स्टीट्यूशनल एरिया, लोधी रोड, नई दिल्ली-110003 टेल: 24360100, फैक्स: 011-24361018  
NTPC Bhawan, SCOPE Complex, 7, Institutional Area, Lodhi Road, New Delhi-110003, वेबसाइट/Website : www.ntpc.co.in

**Performance Bank Guarantee (PBG) Format**

(This format shall be required after placement of PO)

**PERFORMANCE SECURITY FORM**

(To be stamped in accordance with Stamp Act)

Bank Guarantee No.....

Date.....

To,

[Owner's Name & Address]

Dear Sirs,

In consideration of the NTPC Ltd., (hereinafter referred to as the 'Purchaser' which expression shall unless repugnant to the context or meaning thereof include its successors, administrators and assigns) having awarded to M/s ..... with its Registered/Head Office at(hereinafter referred to as the 'Seller' which expression shall unless repugnant to the context or meaning thereof, includes its successors, administrators, executors & assigns) a Contract by issue of Purchaser's Order No..... dated ..... and the same having been unequivocally accepted by the seller resulting in a 'Contract' valued at .....for..... (scope of work/contract) and the seller having agreed to provide a contract performance guarantee/Security Deposit of the faithful performance of the entire contract equivalent to **Rs. (amount in words)\*\*** to the purchaser.

We, .....(Name & Address of Bank ).....

having our Head Office..... at

..... (hereinafter referred to as the 'Bank' which expression shall unless repugnant to the context or meaning thereof, include its successors, administrators, executors & assigns), do hereby guarantee and undertake to pay the Purchaser, on demand any and all monies payable by the Seller to the extent of..... as aforesaid at any time up to..... (\*) without any demur, reservation contest, recourse, or protest and/or without any reference to the Seller. Any such demand made by the Purchaser on the Bank shall be conclusive and binding notwithstanding any difference between the Purchaser and Seller or any dispute pending before any court Tribunal, Arbitrator or any other Authority. The bank undertakes not to revoke this guarantee during its currency without previous consent of the purchaser and further agrees that this guarantee herein contained shall continue to be enforceable till the purchaser discharges this guarantee.

The Purchaser shall have the fullest liberty without affecting in any way the liability of the Bank under this guarantee, from time to time to extend the time for performance of Contract by the Seller. The Purchaser shall have the fullest liberty, without affecting this guarantee to postpone from time to time the exercise of any powers vested in them or of any right which they might have against the Seller, and to exercise the same at any time in any manner, and either to enforce or to forbear to enforce any covenants, contained or implied in the contract between the Purchaser and the Seller or any other course of remedy or security available to the Purchaser. The Bank shall not be released of its obligations under these presents by any exercise by the Purchaser of its liberty with reference to the matters aforesaid or any of them or by reason of any other act or forbearance or other acts of omission or commission on the part of the purchaser or any other indulgence shown by the Purchaser or by any other matter or thing whatsoever which under law would, but for this provision, have the effect of relieving the Bank.

The Bank also agrees that the purchaser at its option shall be entitled to enforce this guarantee against the bank as a principal debtor, in the first instance without proceeding against the seller and notwithstanding any security or other guarantee that the purchaser may have in relation to the seller's liabilities.

Notwithstanding anything contained hereinabove our liability under this guarantee is restricted to..... and it shall remain in force up to and including ..... (\*)..... and shall be extended from time to time for such period (not exceeding one year), as may be desired by M/s..... on whose behalf this guarantee has been given.

Dated this ..... day of ..... 20 .....at

.....

WITNESS

1) SIGNATURE .....

SIGNATURE .....

NAME .....

NAME .....

OFFICIAL ADDRESS .....

DESIGNATION .....

BANK'S COMMON SEAL

2) SIGNATURE .....

ATTORNEY AS PER POWER OF ATTORNEY

NAME .....

NO.....

OFFICIAL ADDRESS .....

DATE .....

**NOTE :**

1. (\*) The Date will be Three Months beyond the expiry of the Contract as specified in the order.

(\*\*) Security deposit @ 5 % of GeM order value

The Bank Guarantee shall be from a bank as per provisions of bidding documents.

2. While getting the Bank Guarantee issued, Bidders are required to ensure compliance to the points mentioned in the Bank Guarantee Verification Check List in the bidding documents. Bidders are required to fill up this check List and enclose the same along with the Bank Guarantee.
3. The Stamp paper of appropriate value shall be purchased in the name of guarantee issuing bank or the party on whose behalf the BG is being issued. The Bank Guarantee shall be issued on non-judicial Stamp paper of appropriate value as per Stamp act prevailing in the States where the BG is to be submitted or is to be acted upon or the rate prevailing in the state where the BG is executed, whichever is higher.
4. The details of secure SFMS (in case of BGs issued from within India) or SWIFT (in case of BGs issued from outside India) sent by Supplier's Bank to Employer's Beneficiary Bank details of which are given in GPC must be furnished with the BG.

**5. PROFORMA FOR EXTENSION OF BANK GUARANTEE**

Ref. No. :

Dated : .....

To

NTPC Ltd.,

.....

.....

**Dear Sirs,**

**Sub. : Extension of Bank Guarantee No. .... Dated ..... for  
.....[indicate value of Bank Guarantee]..... favouring yourselves,  
expiring on..... on account of M/s .....(Name of Bidder)..... in  
respect of Contract for (Insert Package Name)..... for (Insert  
Project Name)..... Project, Contract No. .... dated  
..... (hereinafter called original Bank Guarantee)**

At the request of M/s ....., we ..... Bank branch office at  
..... and having its head office at ..... do hereby extend our  
liability under the above mentioned Guarantee No. .... dated..... for a further  
period of ..... years/months from ..... to expire on .....

Except as provided above, all other terms and conditions of the original Bank Guarantee No.  
..... dated ..... shall remain unaltered and binding.

Please treat this as an integral part of the original guarantee to which it would be deemed to  
have been attached.

(Signature).....

(Name).....

(Designation with .....

Bank Stamp)

Authorised vide

Power of Attorney No.....

Date.....

Dated .....

**Seal of Bank**

**Note:** 1. The extension of the Bank Guarantee should be forwarded to the Unit/ Project/  
Corporate Centre, from where the extension has been sought.

2. The extension of BG should be on Non-Judicial Stamp paper/ e-stamp paper of  
appropriate value as per Stamp Act prevailing in the State(s) where the BG is  
submitted or is to be acted upon or the rate prevailing in the State where the BG is  
executed, whichever is higher. The Stamp Paper/ e-Stamp Paper shall be  
purchased in the name of Bidder/ Bank issuing the guarantee.

**NTPC Limited**  
( A Government of India Enterprise )

**Tender Enquiry No.** 9900278268

**Bill of Materials**  
-----

**Delivery Address:**

Ramagundam Super Thermal Power

PO JYOTINAGAR

DISTRICT PEDDAPALLI

Telangana

505215

India

Tel : 08728-272645/272674 Fax: 08728-272656/272094

Item	Material Code	Description	UoM*	Total Quantity	Delivery Date
00010	M4662110055	GRINDING BALL,BOILER	NO	100.000	30.06.2024
00020	M4662110064	HOLLOW FILLER BALL,BOILER	NO	10.000	30.06.2024
00030	M4662110161N	GRINDING RING,SAO-MO2-SM-A3K-728-2	SET	10.000	30.06.2024

( UOM Legends :- NO - Number , SET - SET )



**Tender Enquiry No.** 9900278268

**TECHNICAL DATA SHEET**

-----

<p><b>00010 - M4662110055</b>  <b>Specification</b>            "BOILER,OEM / PARTS            PART NAME :HOLLOW GRINDING BALL            DIMENSION :654 X 125 MM            SUB ASSEMBLY :BOWL/RACE MILL            EQUIPMENT NAME :200/210 MW BOILER            TYPE:UNMACHINED,MODEL NUMBER:8.5E10"</p>
<p><b>00020 - M4662110064</b>  <b>Specification</b>            "BOILER,OEM / PARTS            PART NAME :HOLLOW FILLER BALL            DIMENSION :585 X 85/90 MM            SUB ASSEMBLY :BOWL/RACE MILL            EQUIPMENT NAME :200/210 MW BOILER"</p>
<p><b>00030 - M4662110161N</b>  <b>Specification</b>            "BOILER,OEM / PARTS            PART NAME :GRINDING RING            DRAWING &amp; POSITION NUMBER :SAO-MO2-SM-A3K-728-2            EQUIPMENT NAME :BOILER            ADDITIONAL INFORMATION :CAPACITY:200/210 MW            FOR LOWER AND UPPER OF 8.5E COAL MILL AND BOWL/RACE MILL"</p>

**Subject : Manufacture and Supply of Set of Grinding Rings & Balls for Ball and race Mill 8.5E10 at NTPC Ramagundam.**

- **Note : Grinding Rings & balls to be supplied in sets by Single Vendor With Guaranteed Working Life Of 4500 Hours .**

**Technical specifications For Grinding ring Set(Top & Bottom)for 8.5E10 Mill for Boiler 200MW**  
(Ref drawing no: SA0-M02-SM-A3K-728-2)

1. Material : The agency may offer material (Ni hard / High chrome) with suitable chemical composition for optimum performance of the grinding rings.
2. The scope of the proposal shall include manufacturing, testing, packaging, transportation, delivery on F.O.R (site) basis of grinding rings for 8.5E10 type coal Pulverisers.
3. Surface condition : Machined
4. Quality of rings shall confirm NTPC accepted quality plan, and shall be assessed after heat treatment and final machined condition.
5. No welding repair will be accepted
6. Castings shall be free from surface defects e.g. sand/slag inclusions, porosity, cold shuts etc. however the following acceptance standards may be used as guidelines during inspection
7. Individual surface defects exceeding 25 mm across and 3 mm deep are not acceptable in non working cast surfaces like inner scattling faces.
8. The surface defects should not be within a linear distance of 200 mm to nearest edge of a lifting pocket.
9. The total defect area should not exceed 3% of the total surface area in which the defects are located.
10. TESTING / INSPECTION:
  - Hardness shall be checked with an accurate tester like "Ultrasonic equipment" or Equivalent equipment directly on the job at minimum 4 to 5 points on ball track area on random basis.
  - Depth of hardness shall be checked on the face where integral test bar is removed.
  - All dimensions and surface finish shall be checked as per NTPC approved drawings.

- Vendor's standard heat treatment cycle for Ni hard, High chrome etc to be followed to achieve required hardness and microstructure.
  - Chemical composition of integral test piece shall be checked in calibrated spectrometer. The integral test piece shall be detached in presence of NTPC inspector during final inspection.
  - NDT i.e DPT, UT etc. are to be performed according to IS/ international standard with acceptance norms
11. After final award of the purchase order the vendor has to submit the quality plan and manufacturing drawing for approval of NTPC. The NTPC drawing is for tender purpose only vide drawing no: SAO-MO2-SM-A3K-728-2
  12. Pre dispatch inspection (PDI) shall be carried out at supplier's works for which supplier shall give minimum 15 days advance intimation to NTPC, RIO and copy of the same shall be marked to NTPC-Ramagundam.

**Technical specifications for  
Set of Hollow grinding balls for 8.5 E10 Mill as per following tech specifications.**

1. The set grinding balls set consists of 10 no. of hollow grinding balls and 1 no. hollow filler ball.
2. The agency may offer material (Ni hard / High chrome etc.) with suitable chemical composition for optimum performance of the grinding balls
3. Outer diameter of grinding balls : 654 +/- 3 mm .
4. Wall thickness of grinding ball : 126 mm +/- 3 mm
5. Outer diameter of filler ball : 585 +/- 3 mm
6. Wall thickness of filler ball : 87 mm +/- 3 mm.
7. Surface condition - unmachined / machined
8. The agency may propose their combination for optimum performance of the balls.
9. NDT, i.e., DPT, UT etc. are to be performed according to is /international standards with acceptance norms
10. Physical and chemical test on integral piece shall be witnessed by NTPC

11. Microstructure analysis is required.
12. Acceptance norm : Surface defects like micro cracks and other inclusions including linear type are permitted to be removed by smooth grinding to a maximum depth of 4 mm. the acceptable percentage of the defective area on total surface area of the ball is up to 20 % of outer surface area of the ball
13. After final award of the purchase order the vendor has to submit the quality plan and manufacturing drawing for approval of NTPC. The NTPC drawing is for tender purpose only vide drawing no:SAO-M02-SM-A3K-793-0
14. PDI shall be carried out at supplier's works for which supplier shall give minimum 15 days advance intimation to NTPC, RIO and copy of the same shall be marked to NTPC-Ramagundam

**GUARANTEE TERMS & CONDITIONS GRINDING RINGS & BALLS:**

1. Both the top ring and bottom ring along with the grinding balls are installed and operate in set , hence guarantee shall be applicable on complete set of Grinding Rings & balls.
2. The vendor shall submit the fitment guarantee / warrantee certificates for the material supplied.
3. The agency should give performance guarantee for minimum 4500 running hours of the grinding element set. The grinding element set means one top ring, one bottom ring, 10 grinding balls and one filler ball.
4. In case of pre-mature failures / evaluated wear life below 3000 running hours, free replacement of grinding element set shall be made including freight, taxes and duties at vendor's scope. Life of such set supplied under free replacement shall be counted from the date of installation of original set.
5. Pre mature failure mean (Within Running hours less than 3000 Hrs) -
  - a) Ball diameter reaches (comes down to) discarding limit  
OR
  - b) Any crack or fracture is found in top ring OR bottom ring OR in Min 02 balls  
Whichever is earlier in 5a OR 5b above
6. The discarding limit / Life completion criteria (with prevailing coal quality at NTPC Ramagundam)-
  - Life of grinding element set shall be considered as completed / Discarding limit shall assumed to be reached when-
    - a. any of the top ring / bottom ring cracks

OR

- b. 02 or more balls broken (in case of breaking of 1 ball vendor has to provide suitable new ball)

OR

- c. grinding ball diameter of the ball comes down to 525 mm or lesser .

Special Notes-

1. Wear of rings shall not be considered for life completion criteria, provided mill loading capacity is not reduced below 26 TPH with required fineness.
2. However, If wear of any of the rings exceed 80 mm, which results in performance deterioration of mill , then life of set shall be considered completed irrespective of ball diameter.
  
7. The average life of total numbers of grinding element sets supplied against the subject purchase order shall be calculated excluding the set covered under pre mature failure as per clause 5 above, if it meets the required guaranteed life after installation of new set. However, if there is shortfall even after installation of new set, shortfall shall be counted in the lot.
  
8. While calculating average life , life of any set beyond GWL shall not be considered, for such set life be taken equal to GWL
  
9. Even if NTPC uses the set beyond specified wear value due to non availability of new set or due to reason of lack of availability of equipment / opportunity for maintenance , Life after attaining above wear value shall not be counted.
  
10. In no case credit/payment for life beyond Guaranteed life of 4500 Hrs shall be given.
  
11. The average wear life of grinding element sets supplied, should be 4500 running hours as per the criteria under clause 6 above . If life comes to less than 4500 running hours, the balance running hours shall be treated as average shortfall of performance.
  
12. Settlement of guarantee terms against PO-
  - Vendor has to supply additional sets of grinding elements ( Rings & balls ) to meet the total cumulative shortfall hours of the po qty. Failing which Pro- rata recovery will be made for any failure/rejection between 3000 to 4500 running hours.

For example

- a. If average actual life = 3700 Hrs (say) against guaranteed life of 4500 hrs , and PO qty is 10 set (say),  
Then ,  
Total cumulative shortfall hours =  $4500 - 3700 = 800$  Hrs/set \* 10 ( PO qty) = 8000 Hrs.
- b. Vendor can settle the recovery through supply of additional sets/ recovery (refund) in full or part with prior consent from NTPC.
- c. For cumulative shortfall of 8000 hours ( as per above example )  
Additional set to be supplied =  $8000 / \text{guaranteed working life}$  .  
 $= 8000 / 4500 = 1.8$   
i.e 2 Nos of sets ( Next higher integer) .
- d. In case if vendor fails to supply the additional sets, pro rata recovery will be done by NTPC for the shortfall life for which sets are not supplied.

For example in above case Vendor may offer to supply

- - 02 additional sets , or
  - - recovery/refund against shortfall life in full i.e 8000 Hrs.
  - 01 additional set for GWL of 4500 and payment recovery against balance 3500 hrs.
- e. Additional sets are to be supplied within 45 days from the date of intimation.
13. Settlement of life shortfall through Material supply or recovery as above shall be done with prior consent of NTPC.
  14. The vendor shall coordinate with site to keep track of grinding ring & balls performance. The scrapped grinding ring will be available on site for one week.  
If vendor is not able to visit site within a week, NTPC will take wear depths of readings at 10 different locations on each ring. The average of reading will be considered as a wear depth of respective ring.
  15. In case of shortfall in performance, equivalent refund (money or material) shall be made by the vendor on for Ramagundam on landed cost basis. Mode of refund shall be solely at the discretion of NTPC.
  16. The old grinding element sets may be returned for premature failure cases at vendor's cost. Vendor may lift the pre-matured failed grinding element set within three months from date of communication from site (only for premature failure cases having life 3000 Hrs), failing which, the same will be added to NTPC scrap and no claims from the vendor will be entertained.

17. The Vendor has to settle the performance short fall within six (06) months from date of communication from NTPC, failing which NTPC shall take necessary action of encashing the Bank guarantee (BG).
18. Supplier may witness the fitment of the set if they so desire. However the set will be installed as per requirement of NTPC and NTPC shall not be required to wait for the presence of vendor's representative at site for fitting the set.
19. Data of installation/removal can be shared on request of vendor during visit of vendors representative at site.
20. Settlement of life shortfall through Material supply or recovery as above shall be done with prior consent of NTPC.
21. TECHNICAL DETAILS OF 8.5E10 PULVERISER
  - Manufacturer : BREDA TERMOMECCANICA
  - Type : Ball & Race (Medium speed)
  - Model : 8.5E10
  - Mill per Boiler: 6 Nos
  - Speed (RPM): 40
  - Design capacity (T/Hr): 26.69
  - No. of coal pulveriser working for MCR : 5
  - Sieve size analysis of pulv. ,coal : 70% through 75mm BS sieve
  - Grinding Balls: 654 mm dia. balls 10 Nos. + 585 mm Filler ball 1 no
  - Loading cylinder gas pressure( kg/sq.cm ) : 34
  - Loading cylinder oil pressure ( kg/sq.cm : 41
  - No. Of loading cylinders per Mill : 8
  - Mill Outlet Temperature (°C) : 80
  - Type of classifier : Static
  - Fineness at mill outlet: Through -200 mesh>70% and Through +50 mesh < 1%
  - Drive arrangement: Spiral bevel helical gear unit Input rpm 970,
    - output rpm 40 , External lubrication



USSC-CPG1

PPG-QA



<b>Standardised Quality Plan</b>	
Item	High Chrome Grinding Ball for 8.5 E10 Coal Mill
SQP No.	CPG-QA-SQP-M-132
Rev	00

GANPATI JHA

Digitally signed by GANPATI JHA  
DN: cn=GANPATI JHA, c=IN, st=Chhattisgarh,  
o=NTPC LIMITED, ou=CONTRACT,  
serialNumber=d3135b18b48ad4b52905337811  
f4c80f1cc904c325d4a9bbf5bb10177c50cae7  
Date: 2022.11.22 09:55:56 +05'30'



.HIGH CHROME GRINDING BALL FOR MILL 8.5E10

MFGR's LOGO	MANUFACTURER'S NAME & ADDRESS:	PROJECT: PACKAGE: P. O. NO: MAIN SUPPLIER:

SI No	Component/ Operations	Characteristics	Class	Type Of Check	Quantum Of Check		Reference Document	Acceptance Norms	Format Of Record		Agency			Remarks
					M	C/N				D	M	C	N	
1	2	3	4	5	6		7	8	9	D	** 10			11

1.0 INPROCESS INSPECTION														
1.1	Castings	Chemical Analysis	Major	Analysis	1/heat	-	Technical specification	Technical specification	Test certificate	√	P	-	V	
1.2		Heat treatment	Major	Visual	100%	-	Technical specification	Technical specification	HT charts	√	P	-	V	
2.0 FINAL INSPECTION														
2.1	Grinding Balls / Filler ball	Chemical Analysis	Critical	Analysis	One / Lot		Technical specification	Technical specification	Inspection report		P	-	W	.To be checked on separately cast test lug identified with casting Heat number
2.2		Metallurgical	Critical	Metallography	One / HT batch		Technical specification	Technical specification	Inspection report	√	P	-	W	
2.3		Surface Hardness	Critical	Test	Each ball	One / HT batch	Technical specification	Technical specification	Inspection report	√	P	-	W	
2.4		Dimensions	Critical	Measure & grade verification by PMI	100%	10%	Technical specification	Technical specification	Inspection report	√	P	-	W	

MFGR's LOGO	MANUFACTURER'S NAME & ADDRESS:	HIGH CHROME GRINDING BALL FOR MILL 8.5 E10	PROJECT: PACKAGE: P. O. NO: MAIN SUPPLIER:
-------------	--------------------------------	--	---

SI No	Component/ Operations	Characteristics	Class	Type Of Check	Quantum Of Check		Reference Document	Acceptance Norms	Format Of Record		Agency			Remarks
					M	C/N				D	M	C	N	
1	2	3	4	5	6		7	8	9	D	** 10			11

2.5	Grinding Balls / Filler ball	NDT	Critical	DPT	100%	10%	ASTM E165	Technical specification	Inspection report	√	P	-	W	
2.6			Critical	UT	100%	10%	ASTM A609	Technical specification	Inspection report	√	P	-	W	
2.7		Visual	Critical	Visual	Each ball	Each ball	SP-55	SP-55	Inspection report	√	P	-	W	

**Note** 1. Reference and acceptance norms shall be derived from following in the same sequence: a) NTPC Approved drawing / data sheet, b) NTPC tech specs, c) Purchase Order , d) Relevant national standard e) Relevant International standard, f) Manufacturer's standard, g) Good Engineering practices.

LOT= Offered quantity

P-PERFORM, V-VERIFICATION, W-WITNESS



USSC-CPG1

PPG-QA



<b>Standardised Quality Plan</b>	
Item	Grinding Ring for Mill
SQP No.	CPG-QA-SQP-M-273
Rev	00

**ANKUSH BIRLA** Digitally signed by ANKUSH BIRLA  
Date: 2024.03.05 11:16:57 +05'30'

MFGR's LOGO	MANUFACTURER'S NAME & ADDRESS:	RAMAGUNDAM MANUFACTURING QUALITY PLAN			PROJECT:
		ITEM: GRINDING RINGS – 8.5E10 COAL MILL	QP NO :	PACKAGE:	
				REV NO :	P. O. NO:
				DATE :	MAIN SUPPLIER:
				PAGE : 1 of 2	

SI No	Component/ Operations	Characteristics	Class	Type Of Check	Quantum Of Check		Reference Document	Acceptance Norms	Format Of Record		Agency			Remarks
					M	C/N			M	C	N	M	C	
1	2	3	4	5	6		7	8	9	D	** 10			11

**1.0 IN PROCESS INSPECTION**

1.1	Castings	Chemical Analysis	Major	Analysis	1/ heat	-	PO Tech. Spec. / NTPC Drg. / Datasheet / Mfg. std.	Test certificate	√	P	-	V	
1.2		Heat treatment	Major	Visual	1/ heat	-	PO Tech. Spec. / NTPC Drg. / Datasheet / Mfg. std.	HT charts/ reports	√	P	-	V	

**2.0 FINAL PRODUCT**

2.1	Rings	Chemical Analysis	Critical	Analysis	1/Lot		PO Tech. Spec. / NTPC drg. / Datasheet / Mfg. std.	Inspection report	√	P	-	W	Integral test piece has to be detached in presence of NTPC representative
2.2		Metallurgical	Critical	Metallography	1/HT batch		PO Tech. Spec. / NTPC Drg. / Datasheet / Mfg. std.	Inspection report	√	P	-	W	
2.3		Hardness	Critical	Test	5 random spots on each ring		PO Tech. Spec. / NTPC Drg. / Datasheet / Mfg. std.	Inspection report	√	P	-	W	
2.4		Dimensional	Critical	Measure	100%	10%	PO Tech. Spec. / NTPC Drg. / Datasheet / Mfg. std.	Inspection report	√	P	-	W	

		<b>LEGEND:</b> RECORDS INDICATED WITH "TICK" (√) MARK SHALL BE ESSENTIALLY INCLUDED BY SUPPLIER IN QA DOCUMENTATION <b>** M:</b> MANUFACTURER/SUB SUPPLIER C: SUPPLIER <b>N:</b> NTPC, P: PERFORM, W: WITNESS, V: VERIFICATION AS APPROPRIATE; CHP: CUSTOMER HOLD POINT		DOC NO:	REV:	CAT
MANUFACTURER / SUB SUPPLIER	MAIN SUPPLIER			FOR NTPC USE	PREPARED / PROPOSED BY	REVIEWED BY
<b>SIGNATURE</b>						

<b>MFGR's LOGO</b>	<b>MANUFACTURER'S NAME &amp; ADDRESS:</b>	<b>RAMAGUNDAM MANUFACTURING QUALITY PLAN</b>			PROJECT:
		<b>ITEM: GRINDING RINGS – 8.5E10 COAL MILL</b>	QP NO :	PACKAGE:	
				REV NO :	P. O. NO:
				DATE :	MAIN SUPPLIER:
				PAGE : 2 of 2	

SI No	Component/ Operations	Characteristics	Class	Type Of Check	Quantum Of Check		Reference Document	Acceptance Norms	Format Of Record		Agency			Remarks
					M	C/N			M	C	N	M	C	
1	2	3	4	5	6		7	8	9	D	** 10			11
2.5		Grade verification	Critical	Grade verification	100%	20%	PO Tech. Spec. / NTPC Drg. / Datasheet / Mfg. std.	Inspection report	√	P	-	W	To be checked with XRF analyser which will be arranged by vendor	
		NDT	Critical	DPT	100% on machined area		ASTM E 165	No Relevant Indication	Inspection report	√	P	-	W	
			Critical	UT	100% on ball track area		ASTM A 609	ASTM A 609 Quality Leve II	Inspection report	√	P	-	W	

**Note:** 1. Reference and Acceptance norms shall be derived from following in the same sequence-

- 1) NTPC Approved drawing / data sheet ; 2) NTPC tech specs ; 3) Purchase Order ; 4) Relevant national standard
- 5) Relevant International standard ; 6) Manufacturer's standard 7) Good Engineering practices

2. On receipt of material at NTPC stores, 10 % items will be checked by NTPC XRF metal analyzer and the material should confirm to the specification.

3. One lot is equal to the offer quantity for inspection.

4. Witness by NTPC/authorized representative (wherever applicable) shall be on randomly chosen sample/s. NTPC shall review Mfrs test report for balance quantity.

		<b>LEGEND:</b> RECORDS INDICATED WITH "TICK" (√) MARK SHALL BE ESSENTIALLY INCLUDED BY SUPPLIER IN QA DOCUMENTATION ** M: MANUFACTURER/SUB SUPPLIER C: SUPPLIER N: NTPC, P: PERFORM, W: WITNESS, V: VERIFICATION AS APPROPRIATE; CHP: CUSTOMER HOLD POINT		DOC NO:	REV:	CAT
MANUFACTURER / SUB SUPPLIER	MAIN SUPPLIER			FOR NTPC USE	PREPARED / PROPOSED BY	REVIEWED BY
<b>SIGNATURE</b>						

SYMBOLS USED TO DENOTE SURFACE ROUGHNESS

OLD METHOD	PRESENT METHOD	0.4	0.8	1.6	3.2	6.3	12.5	25	50
------------	----------------	-----	-----	-----	-----	-----	------	----	----

REF DRAWING FOR TENDER PURPOSE ONLY

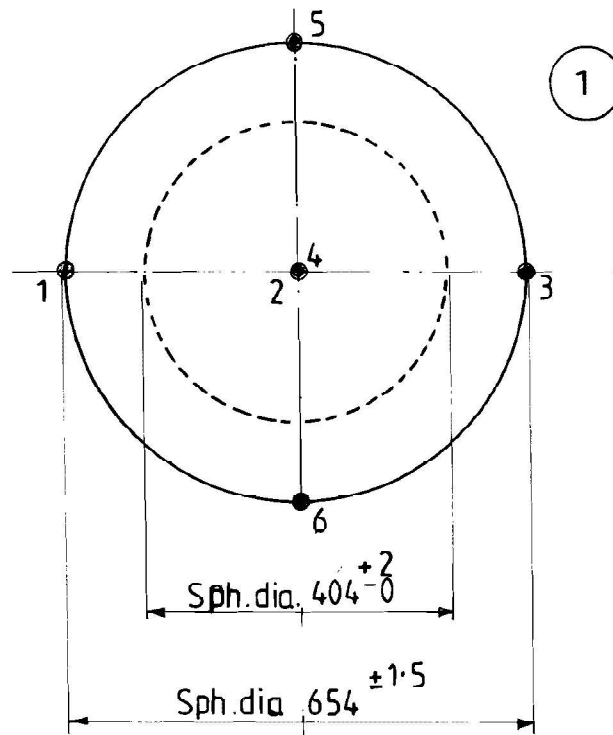

**NOTES :-**

1. Core diameter must be concentric within  $\pm 3$
2. Core holes to be plugged. Plug to be welded in place.  
Core sand can be left within ball.
3. HARDNESS: Refer Tech Specifications
4. HARDNESS READING: 6 Readings to be taken as shown.  
2 & 4 are diametrically opposite.
5. Heat no & Make to be embossed inside the ball.

2	FILLER BALL $\phi 585 \pm 1.5$	1	Ni-Hard:IV		
1	Hollow spherical ball	10	Hi-Chrome	711	
PART No.	DESCRIPTION	QTY	MATERIAL	UNIT WT IN K.G.	REMARKS
<b>PARTS LIST</b>					

SIGN/DATE

REVISIONS



**RAMAGUNDAM SUPER THERMAL POWER STATION**

(A GOVERNMENT OF INDIA ENTERPRISE)

SKETCHED	PROJN.		TITLE	HOLLOW GRINDING BALL FOR
DRAWN <i>meegul</i>	DATE	05-08-1994	8.5E 10 COAL MILL	
CHECKED	SCALE	1:10		
APPROVED <i>Chava</i>	DEPT.	O & M Plg.	DRAWING	No. REV.

- GENERAL NOTES:**
1. ALL DIMENSIONS ARE IN 'mm' UNLESS SPECIFIED
  2. DO NOT SCALE THE DRAWING
  3. WELDING SYMBOLS AS PER IS.813
  4. ALLOWABLE DEVIATIONS FOR DIMENS: WITHOUT SPECIFIED TOLERANCES FOLLOW IS.2102/1969

SAO	M02	S	M	A	3	K	793	0
CALL No.	1039	SHEET	1	OF	1			

CI-R6-F6

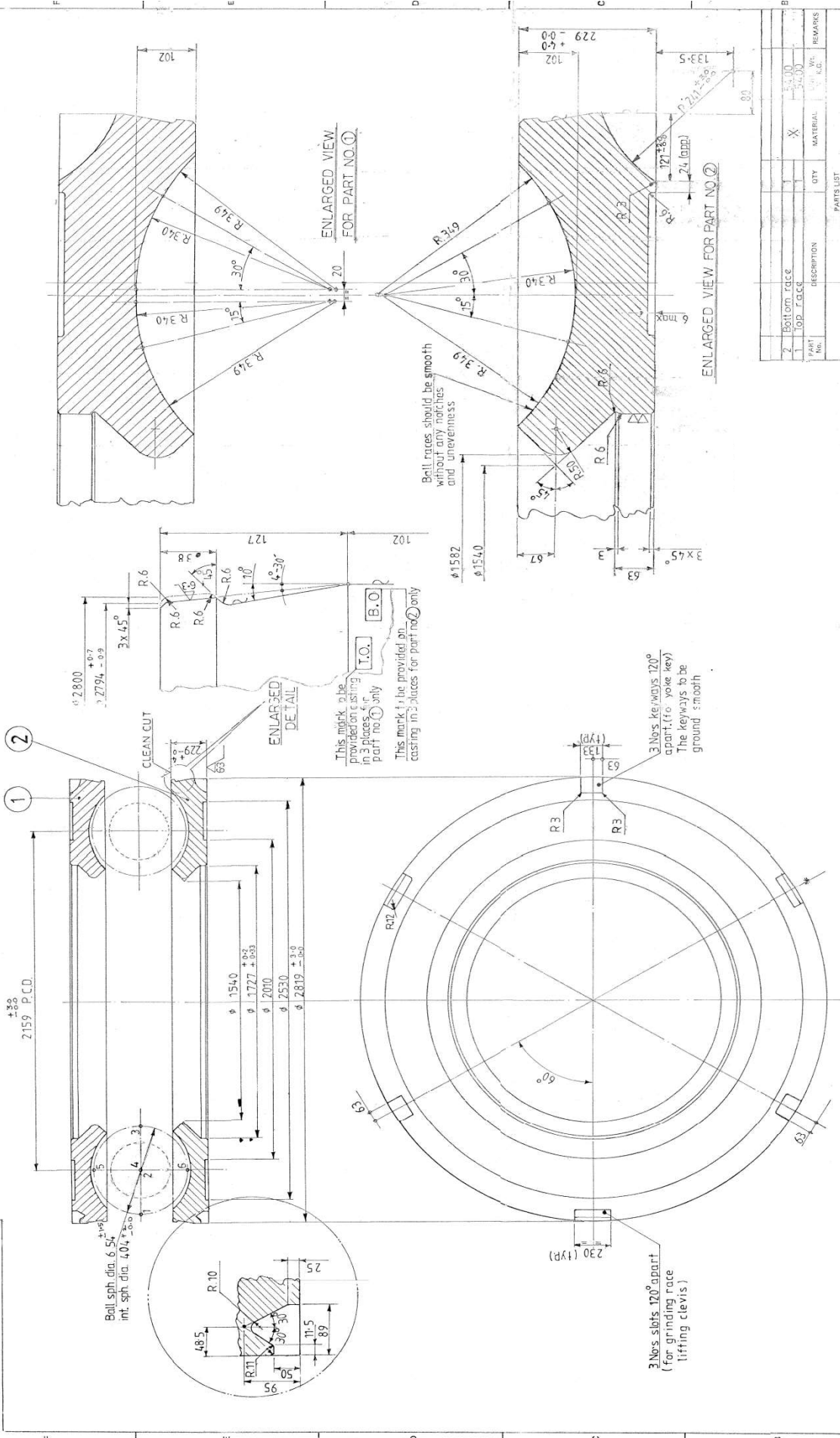

**\* NOTE :-**

- Band ring provision to made on bottom ring with lifting third size of M24 at equal spaced
- For Top ring both lifting pockets & Band ring is not required

**\* NOTE :-**

- Landing face to be flat within 0.003" by st. edge check.
- Inner landing band to be in level or below outer land face by 0.004" + Bell race surface to be smooth with out any notches and unevenness.

**RAMAGUNDM SUPER THERMAL POWER STATION**  
(A GOVERNMENT OF INDIA ENTERPRISE)

**ASSEMBLY FOR 85.1.3 COAL MILL**

DESIGNED:  PROJUN.  DATE: 20.11.1980  
 DRAWN:  CHECKED:  SCALE: NTS  
 APPROVED:  DEPT. O&M, PIG.

**GENERAL TOLERANCES FOR DIMENS UNLESS OTHERWISE STATED**

ANGLES	0 - 100	0.2	3.00 ± 0.1 mm (in)	0.05
101 - 250	0.3	OTHERS ± 18 (in)	0.05	15, 25, 30, 45, 60, 90
251 - 500	0.4	KEYWAYS ± 0.10 (in)	0.05	15, 25, 30, 45, 60, 90
501 - 1000	0.5	KEYWAYS ± 0.15 (in)	0.05	15, 25, 30, 45, 60, 90
1001 - 1500	0.75	KEYWAYS ± 0.20 (in)	0.05	15, 25, 30, 45, 60, 90
1501 - 2000	1.0	KEYWAYS ± 0.25 (in)	0.05	15, 25, 30, 45, 60, 90
ABOVE 2000	1.3	KEYWAYS ± 0.30 (in)	0.05	15, 25, 30, 45, 60, 90

**REFERENCE DRAWINGS**

NO.	DESCRIPTION
1	STATE
2	STATE
3	STATE

**ADDITIONAL INFORMATION**

REV. / PAGES: 1 / 1

REVISIONS: 1

SIGNATURE: \_\_\_\_\_

**PARTS LIST**

Part No.	DESCRIPTION	QTY	MATERIAL	UNIT	REMARKS
2	Bottom race	1	X	52.00	
	TOP RACE	1	X	52.00	

**DRAWING:** SAO M02 SM A3K 728

SIZE: A7 504 x 420